

XANAS[®]

Counter-Current System

GB Operator`s Manual

Translation of the original

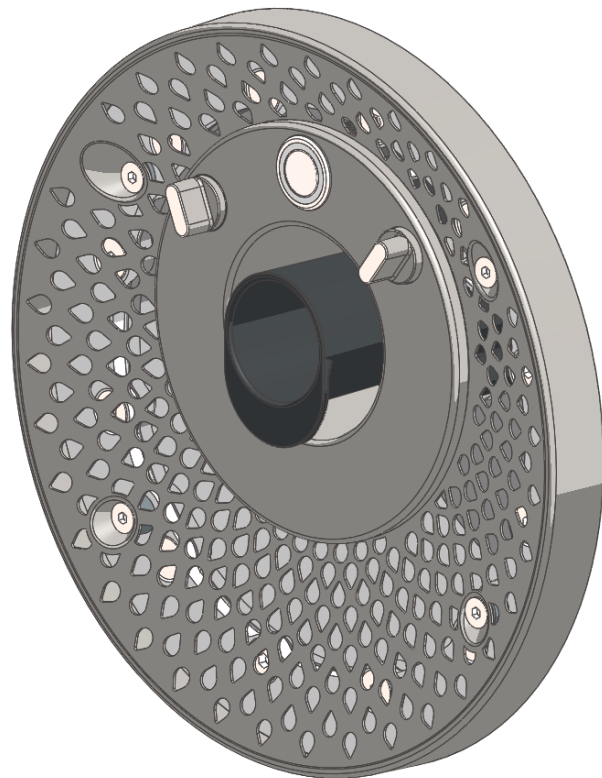

27258-E

Table of Contents

1. General information	4
1.1. Warranty notice	4
1.2. General information.....	4
1.3. Proper use	4
2. Safety Instructions	6
2.1. General information.....	6
2.2. Marking	6
2.3. Safety instructions for the operator	7
3. Description of the device / general technical data	8
3.1. Technical data for pump kit (sample selection	8
3.2. Pipe dimensioning.....	9
3.3. Device Units.....	11
3.4. Abbreviations	11
4. Other applicable documents	11
5. Installation instructions for installation kit (isolated design)	12
5.1. Planning the pump shaf	12
5.2. Scope of delivery	14
5.3. Installation depth	15
5.4. Preparation for installation preassembled pool	15
5.5. Preparation for installation preassembled pool	17
5.6. Preparation for installation of stainless steel pool	18
5.7. Concrete pool (tiled – with or without liquid seal, liner).....	19
5.8. Preassembled pool.....	20
5.9. Stainless steel pool.....	21
5.10. Pipeline adapter / pump connection.....	21
5.11. Retro-fitting	24
6. Assembly kit installation instructions	25
6.1. Assembly (general).....	25
6.2. Assembly of concrete pool (tiled - with or without liquid seal)	27
6.3. Concrete pool (liner)	29
6.4. Preassembled pool.....	30
6.5. Stainless steel pool.....	30
7. operation	31
7.1. Switching On/ Off.....	31
7.2. Regulating the intensity	31
8. Troubleshooting	33
9. Taking out of operation / winter storage	34
9.1. Draining the pool.....	34
9.2. Winter storage of the nozzle head.....	35
9.3. Draining the Pump	35
10. Maintenance and repairs	36
10.1. General information	36

10.2.	Maintenance	36
10.3.	Repairs.....	36
11.	Exploded drawings – overview of parts/ spare	37
11.1.	Installation kit PU	37
11.2.	Installation kit INOX	37
11.3.	Assembly kit ABS – manual control	38
11.4.	Assembly kit INOX – manual control	38
11.5.	Assembly kit ABS – sensor control.....	39
11.6.	Assembly kit INOX – sensor control.....	39

1. General information

1.1. Warranty notice

Failure to comply with the information provided in this operator's manual voids all claims under warranty.

1.2. General information

All parts in contact with media are designed for water quality according to DIN 19643.

This counter-current system (XANAS[®]) represents the state of the art. It has been manufactured with the greatest care and is subject to continuous quality control.

This Operator`s Manual contains important information to ensure that the counter-current system is operated safely, properly and economically. Your strict observance is necessary to prevent dangers and ensure a long service life for the counter-current system.

This operator's manual does not take into consideration local requirements. The operator is responsible for ensuring these requirements are met, including personnel retained to assemble the system.

The rating plate indicates the series and frame size, the most important operating data and the factory number. If additional information is required, please always specify it when reordering or ordering spare parts.

1.3. Proper use

The counter-current system was designed for use in private swimming pools. Therefore it should not be installed in public swimming pools. The entire system or parts of it are not suitable for use in other systems. Accordingly we explicitly instruct you only to use such parts or the entire system for their intended purpose.

The counter-current system must not be operated beyond the values specified in technical data (3.1). If you have any questions, please contact your Customer Service representative or the manufacturer.

Not suitable for salt electrolysis systems.

Partially suitable for salt electrolysis systems.

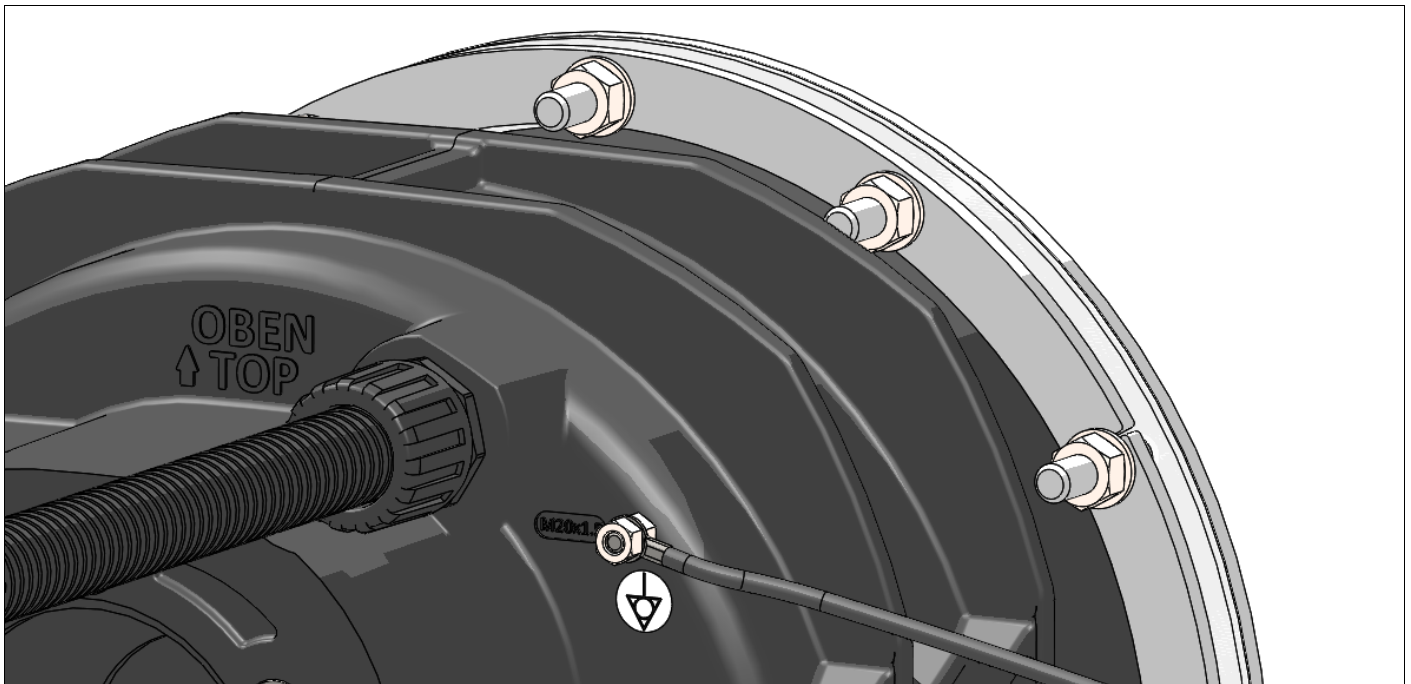

Fig. 1 Installation housing equalizing tension point (example PU)

	Chlorinated water	Salt electrolysis	Brine-/ sea water
Equalizing tension	E	W	E
Sacrificial anode	-	E	E

E ≙ Recommendation

W ≙ Important



Important note!

Make certain when the pool is emptied that no direct sunlight strikes the plastic elements. Cover immediately!

2. Safety Instructions

2.1. General information

- Make certain before commissioning that the operating personnel have read and understood the operator's manual. It is the owner rather than the operator who is responsible for safety.
- Make certain the safety requirements and laws for the use of counter-current systems which apply to the operating company and/or country in which the system is operated are observed.
-
- All parts that come in contact with medium are resistant up to an absolute salt content of 3000 mg/l Cl-. If higher concentrations of salt are present, please contact the manufacturer.
- Use the counter-current system only when it is in flawless condition technically and according to its intended purpose. Be conscious of safety and dangers and observe all the instructions of this Operator`s Manual!
- Eliminate all malfunctions that could have a detrimental effect on safety immediately.
- Before making repairs to the counter-current system, disconnect it from its electrical power source and prevent it from being turned on again!
- Repairs of any nature must only be made by qualified specialists. The counter-current system must also be emptied.
- The operator must ensure that
 - the operator's manual is always available for operating personnel,
 - the instructions in the operator's manual are observed,
 - the counter-current system is stopped immediately if any abnormal electrical voltages, vibrations, temperatures, noises, vibrations, leaks, or other faults occur.

2.2. Marking

The following symbols are used in this operator's manual to make special reference to dangers.

	<p>Caution! Risk of injury! / Attention! Risk of damage! This symbol warns of hazards due to mechanical effects and of actions that will damage the product.</p>
--	---

	<p>Caution! Danger of death! This symbol warns you of dangers due to electrical current.</p>
--	---

	<p>Important note!</p>
--	-------------------------------

Notices placed directly on the pump, such as the arrow for direction of rotation, must always be observed and must be maintained in legible condition.

2.3. Safety instructions for the operator

Electrical equipment must only be installed and serviced by qualified personnel.

Applicable safety regulations and equipment requirements at the installation site must be observed.

The term qualified specialist (Fachkraft) is defined in VDE 0105 and IEC 364. This operator's manual does not contain any information for non-qualified persons.

We explicitly draw to your attention that the stipulations of the EC prohibit the use of non-qualified persons on electrical systems.

	<p>Danger of lethal electrical current! Electrical connections must only be made by a professional electrician in accordance with VDE Regulation 0100. Observe the local requirements of the responsible electrical power provider as well as standards and safety requirements for electrical systems in swimming pools. Comply with DIN EN 13451!</p>
---	---

	<p>Note! Comply with DIN EN 13451 in the design of the suction unit.</p>
---	---

3. Description of the device / general technical data

- The counter-current system meets the requirements of the VDE regulations.
- The electric motor and pump through which water flows are electrically separated.
- The electric motor corresponds to protection type IP 55.
- The counter-current system as a whole meets the requirements of protection class I.

3.1. Technical data for pump kit (sample selection)

System type:	XANAS® 1,5	XANAS® 1,5 WS	XANAS® 1,9 (FU)	XANAS® 1,9 WS	XANAS® 2,2 WS	XANAS® 3,0 (FU)	XANAS® 4,0 (FU)
Output	1,5 kW	1,5 kW	1,9 kW	1,9 kW	2,2 kW	3,0 kW	4,0 kW
Mains voltage	3~ 400 V	1~ 230 V	3~ 400 V	1~ 230 V	1~ 230 V	3~ 400 V	3~ 690 V
Mains frequency	50 Hz (60 Hz)						
Motor voltage	Δ230V Y400V	230 V	Δ230V Y400V	230 V	230 V	Δ230V Y400V	Δ400V Y690V
Rated current (I _{max})	2,9 A	9,5 A	4,1 A (4,6 A)	11,5 A	13,0 A	6,6 A (6,2 A)	8,5 A (7,9 A)
Speed	(1.200 -) 2.900 min ⁻¹						
max. pump capacity	700 l/min (42 m ³ /h)		800 l/min (48 m ³ /h)		900 l/min (54 m ³ /h)	1.000 l/min (60 m ³ /h)	1.200 l/min (72 m ³ /h)
max. delivery pressure	1,2 bar		1,4 bar		1,5 bar	1,9 bar	2,0 bar
max. water temperature	50° C						
Usage limit (pump only)	4.500 mg/l Cl						
expected acoustic pressure level	65 +2dB(A)		67 +2dB(A)			70 +2dB(A)	71 +2dB(A)
Connections	Druckseite DN50 / Saugseite DN 65						
Weight	27,5 kg		29,5 kg (38 kg)			36,5 kg (45 kg)	43 kg (51 kg)
Item no. PBS	98420	98421	98422 (98390)	98423	98424	98425 (98391)	98426 (98392)

Definition of abbreviations used

WS - Single-phase alternating current motor (German Wechselstrommotor)

FU - Frequency inverter (German Frequenzumrichter), drive controller, speed-controlled pump

3.2. Pipe dimensioning

3.2.1. Flow speeds

To prevent impacts due to acceleration or delay, the flow speed should be kept uniform in the pipelines. The following approximate values are cited in the relevant sources (for pipework up to 6m, the following exemplary recommendations apply):

Empfohlene Flow speed (by Water)		42 m ³ /h	48 m ³ /h	60 m ³ /h	72 m ³ /h
Suction line	1,0 – 1,5 m/s	DN 100	DN 125	DN 125	DN150
Pressure line	2,5 – 3,0 m/s	DN 65	DN 80	DN 100	DN 100

An economical speed is the determining factor for the dimensioning. It is derived from the optimum of the total of investment costs for the pipeline, the investment costs for the machine system (pumps, compressor) and the energy and maintenance costs over the entire operating time.

	<p>Note! For pipelines longer than 6m, the nominal width must be enlarged, for example on the suction side from DN100 to DN125 and on the pressure side from DN80 to DN100. To keep pipeline resistances as low as possible, always use pipelines with bends, not angles, and use 45° T-pieces instead of 90° T-pieces.</p>
--	---

3.2.2. Flow Losses - Pipes and Elements

Water, 48 m³/h; turbulent flow; roughness value: 0.1 mm

Flow losses in the entire pipeline (pressure and suction side) must be noted.

Flow losses must be kept low in the components that are used.

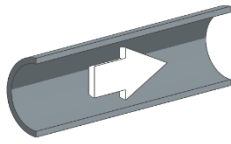

Pipe, 30 m, PVC hard, DIN 19532	Pressure loss	Flow speed
DN 80	0,263 bar	2,562 m/s
DN 100	0,095 bar	1,718 m/s
DN 150	0,014 bar	0,812 m/s

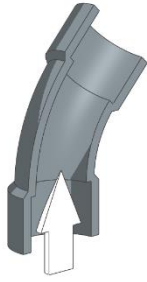

DN 80	Pressure loss	Flow speed
45° Pipe bend	0,015 bar	2,562 m/s
90° Pipe bend	0,006 bar	2,562 m/s

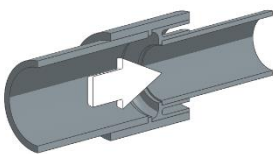
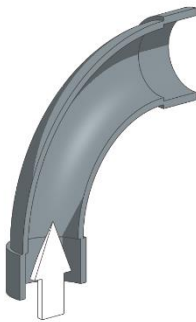

DN 80	Pressure loss	Flow speed
Abrupt pipe contraction DN80 to DN50	0,278 bar	2,562 m/s
edged run-in under angle	0,027 bar	2,562 m/s

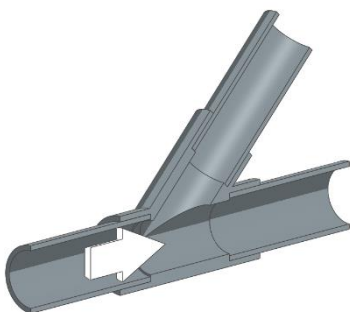

Fig. 2 Sample flow values

3.3. Device Units

The counter-current system is delivered in 3 modules:

1. Pump kit
2. Installation kit
3. Assembly kit

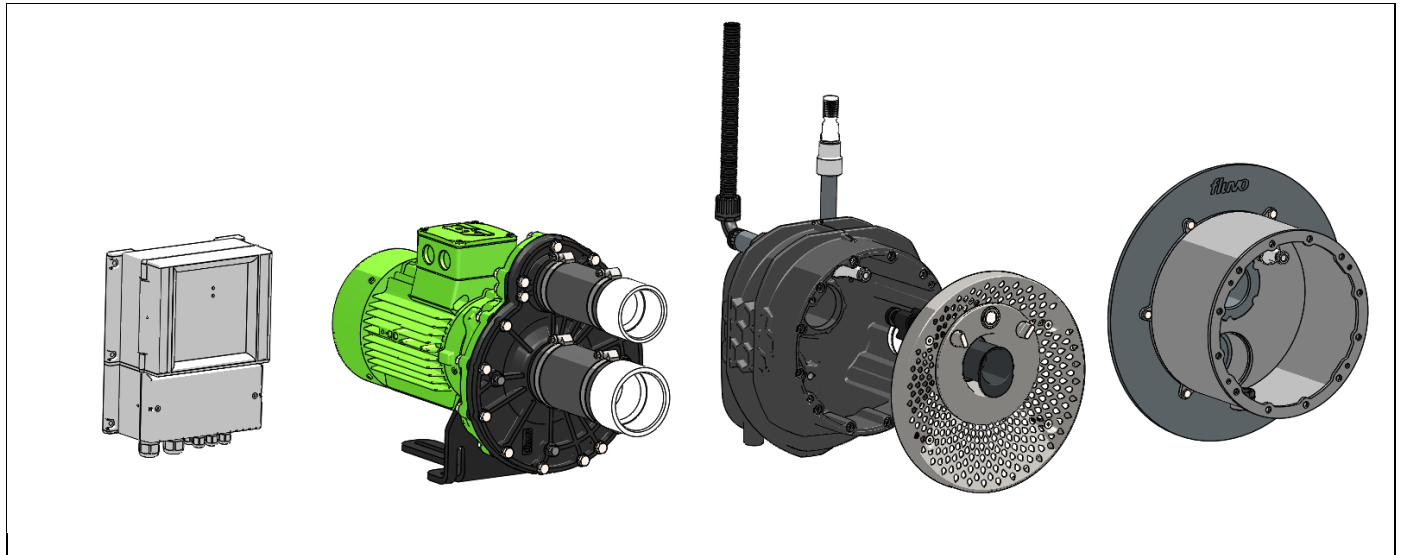

Fig. 3

The installation kit and the assembly kit are always different and depend on the type of pool. The pump kit is available in an isolated design.



Note!

For details regarding assembly and connecting the pump kit see Operator's Manual 27220.

3.4. Abbreviations

- A Preassembled pool (GFK, PP, PVC, or similar)
- B Concrete tile pool
- H Concrete liner pool
- S Concrete tile pool, with and without liquid sealing
- E Stainless steel pool (to be welded on)

4. Other applicable documents

- No. 27220 - Operator's Manual for WK
- No. 27248 - Operator's Manual for control box
- No. 27263 - Operator's Manual for XANAS[®] electrical installation
- No. 27251 - Operator's Manual for converter box
- No. 27136 - Operator's Manual for drilling templates
- To place a FU-controlled system in operation, follow the instructions in the "INVEOR Drive Controller" Operator's Manual.

<http://www.kostal-industrie-elektrik.com/de-DE/Download/Antriebstechnik>

5. Installation instructions for installation kit (isolated design)

5.1. Planning the pump shaft



Note!

Ensure a sufficiently large and ventilated pump shaft or technical room.

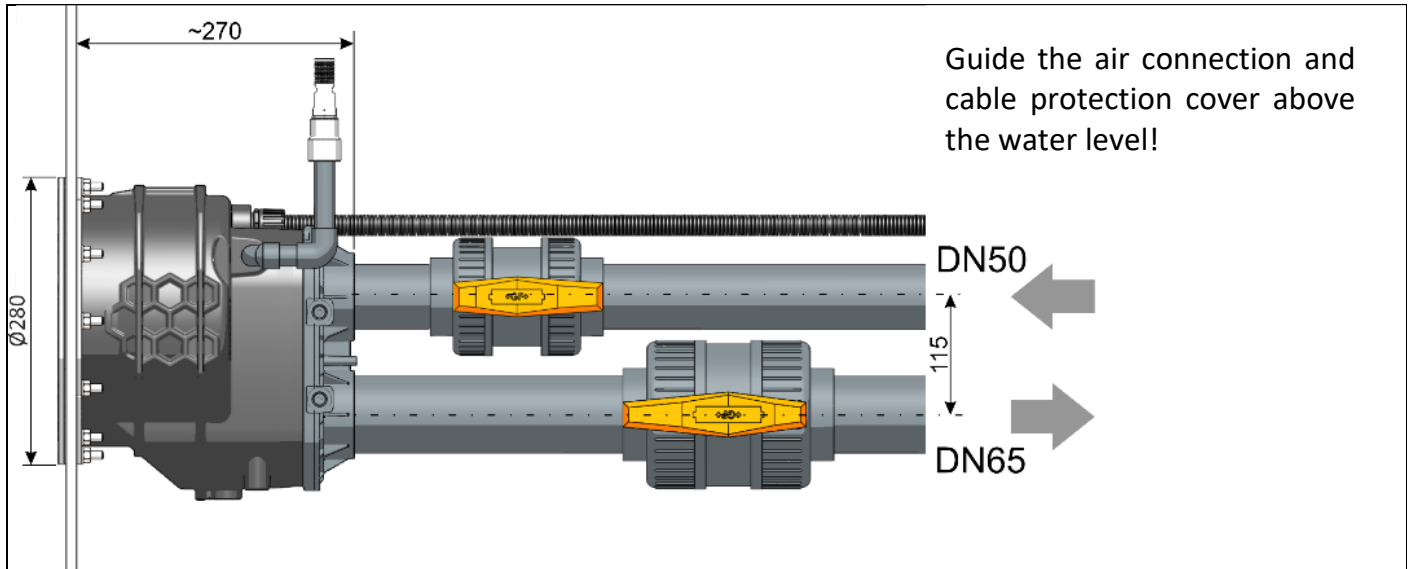
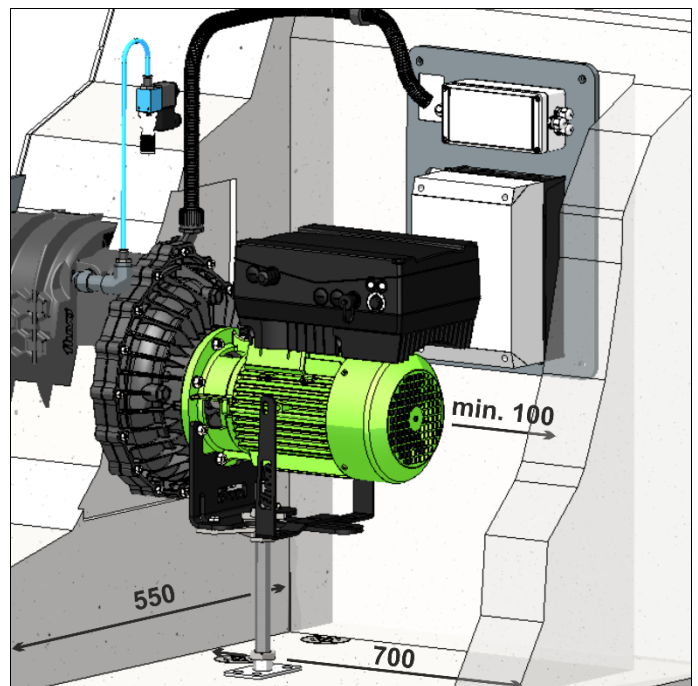
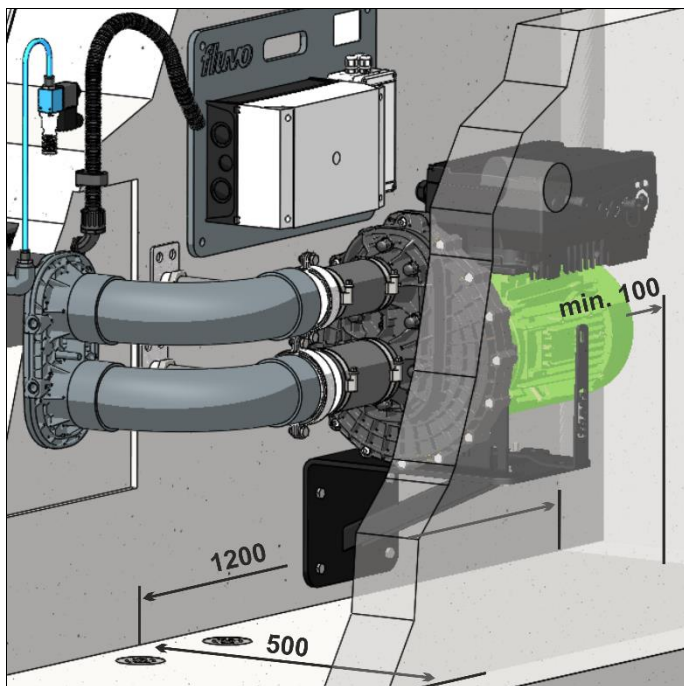
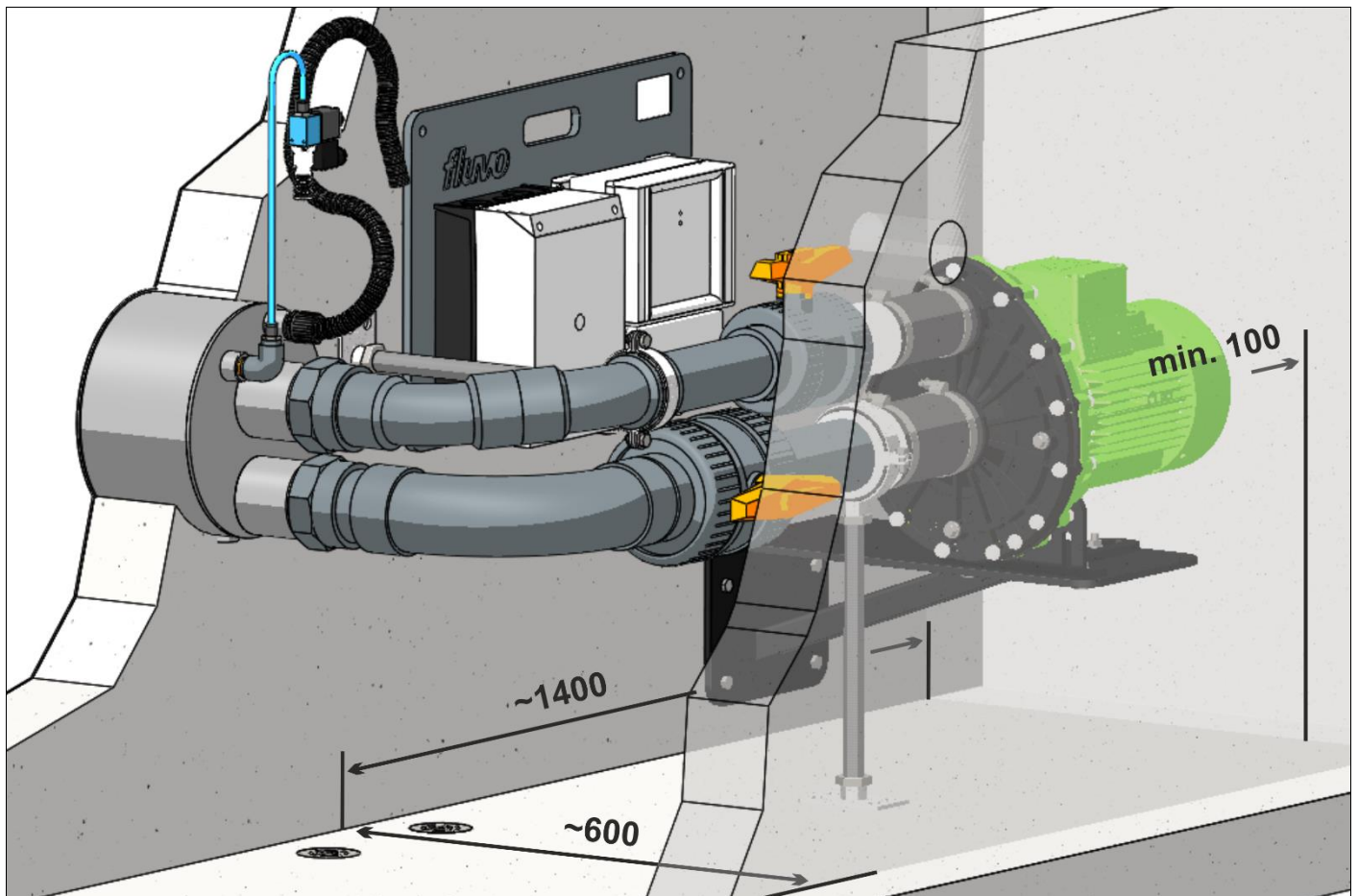
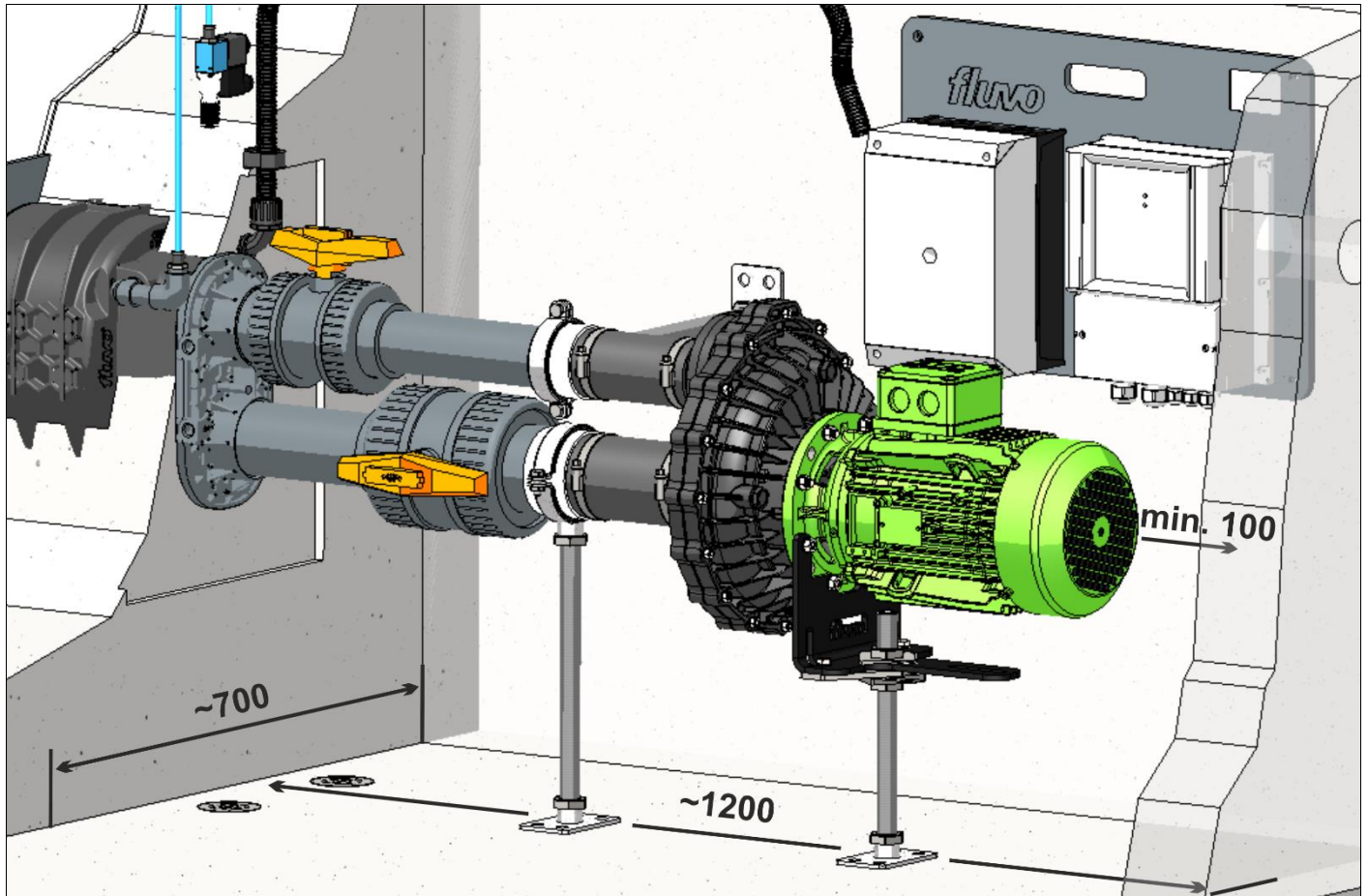

Fig. 4 Installation suggestion for isolated design (figure: preassembled pool design)

Below are some installation suggestions





5.2. Scope of delivery

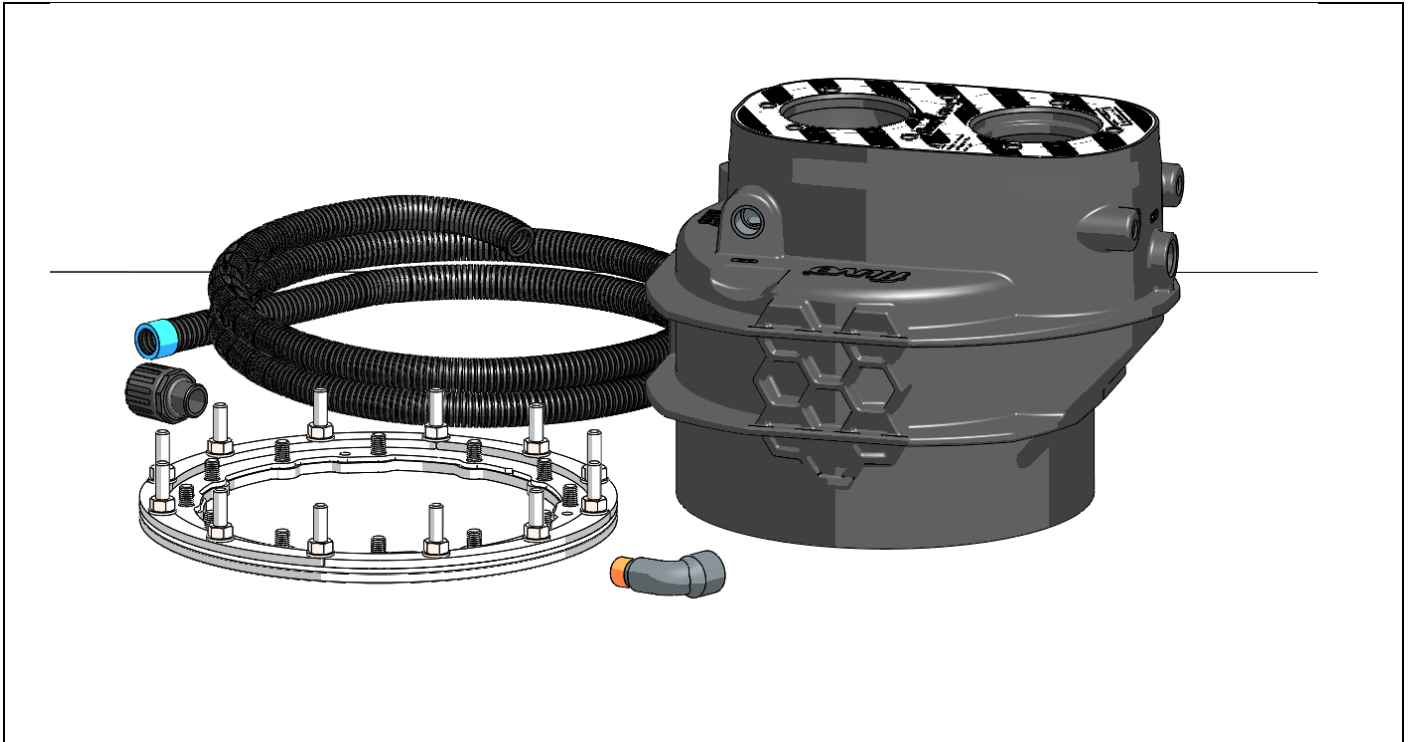

Fig. 5 Preparation for installation (picture exemplary)

- Installation housing (in some cases with clamping ring or similar device)
- PVC pipe connections
- Cable protection system
- Air connection and check valve
- Liquid seal for plastic thread
- Possible tool



Note!

Seal the plastic thread with suitable liquid seal.

Article no. 70254 (thread and 100ml tube sealing) is included with the installation kit (depending on design)!

5.3. Installation depth

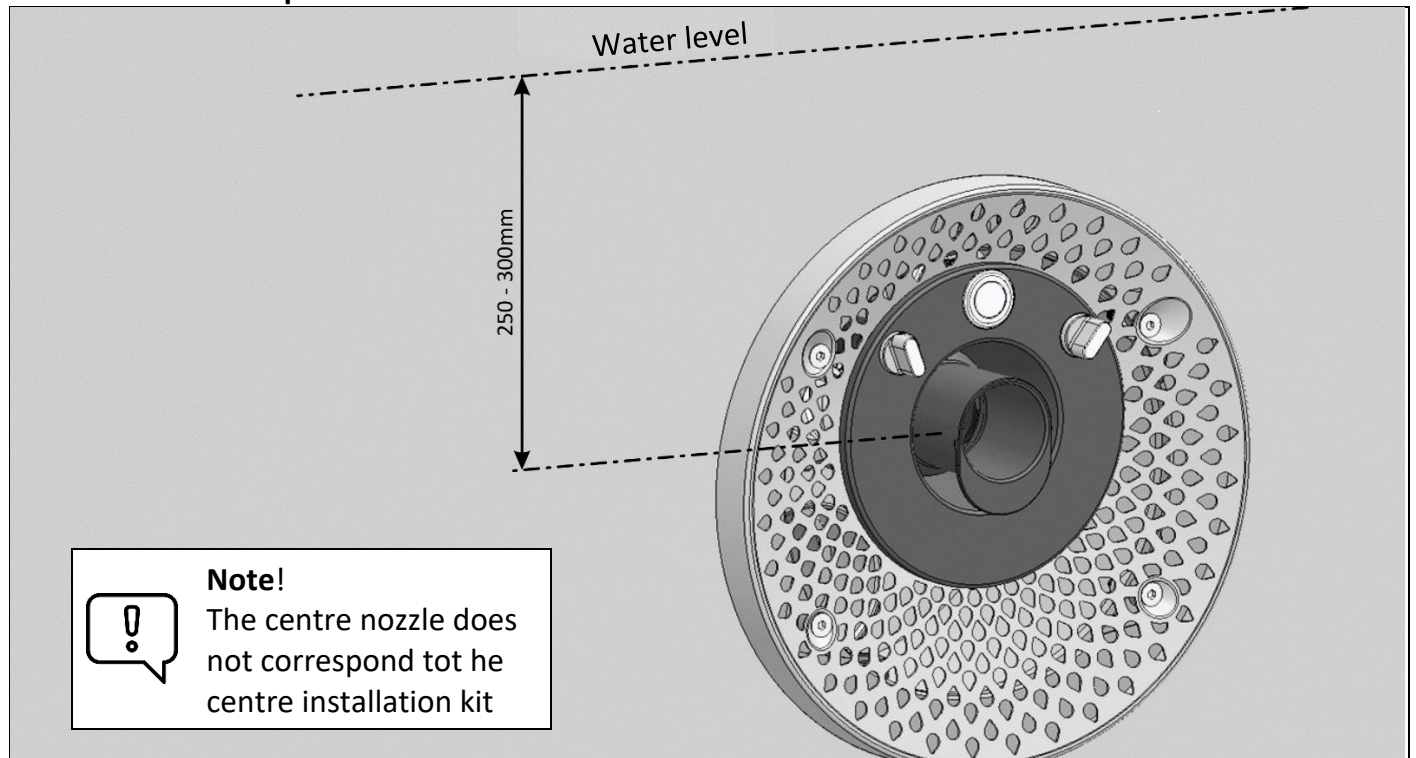

Fig. 6

5.4. Preparation for installation preassembled pool

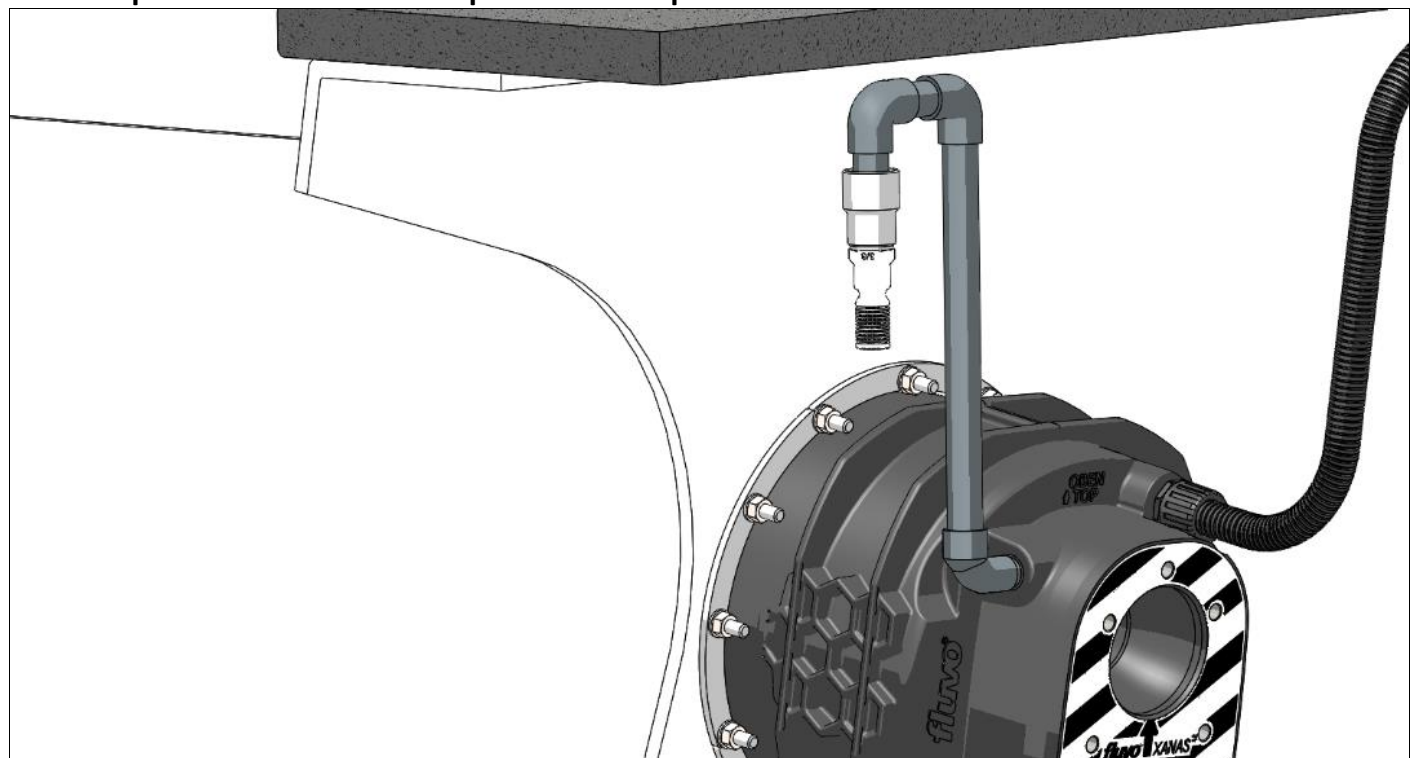



Fig. 7 Air connection and cable protection

	<p>Note! Guide the air connection and cable protection cover above the water level!</p>
---	--

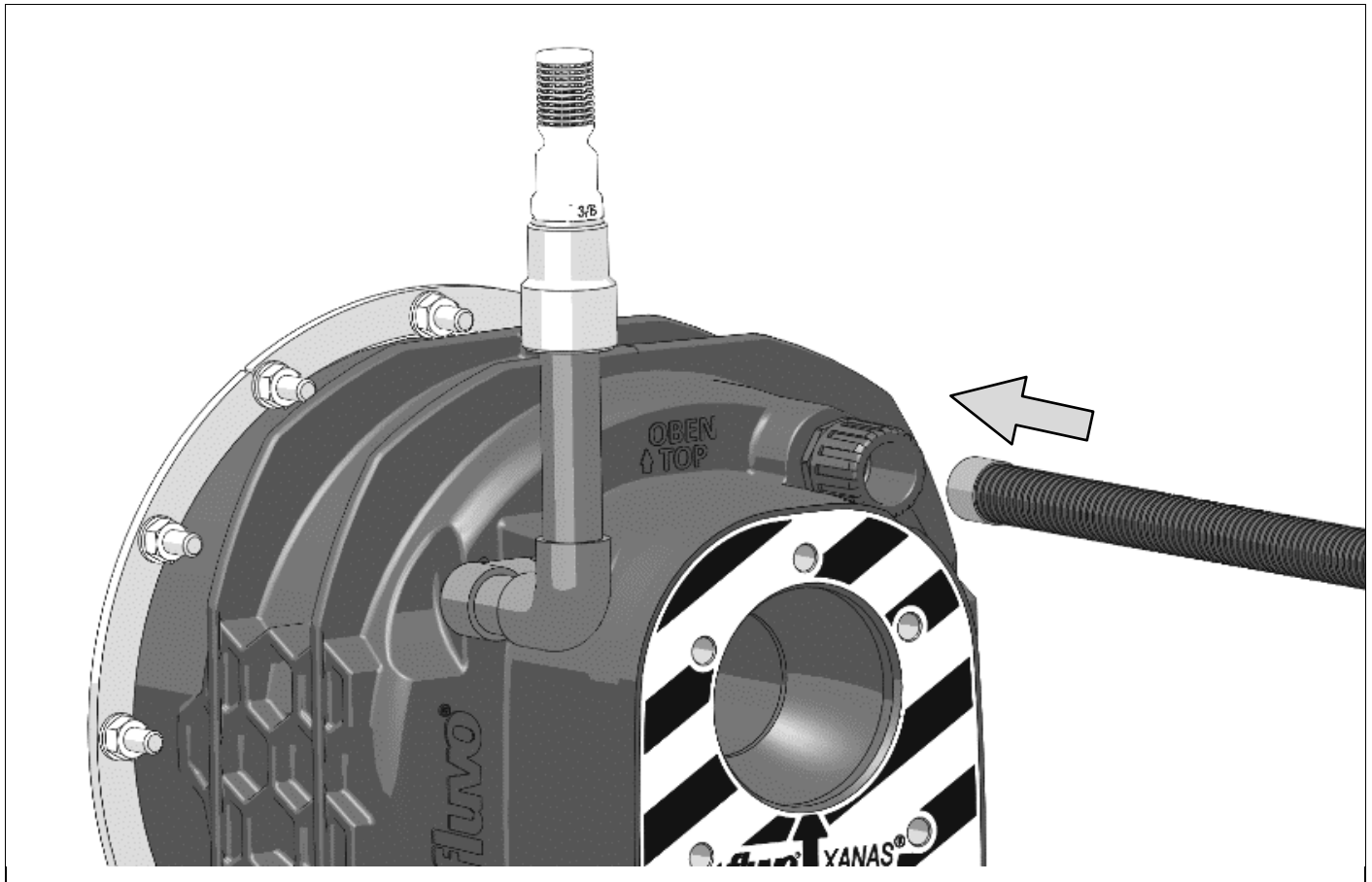

Fig. 8



Note!

Install the cable protection system securely (before backfilling or concrete work)!



Attention!

Do not remove the protective sticker until the pipeline is installed!

5.5. Preparation for installation preassembled pool

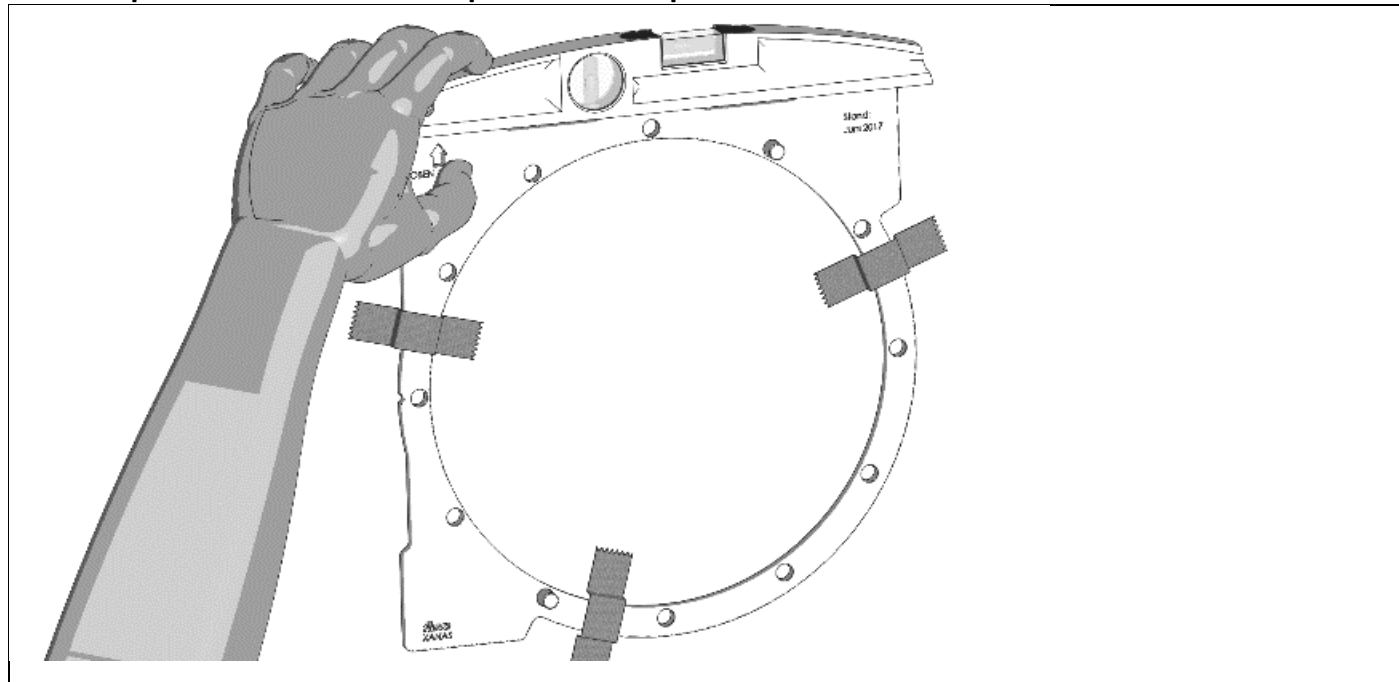

Fig. 9 Drilling template for preassembled pool



Note!

Note the Operator's Manual for drilling templates (27136)

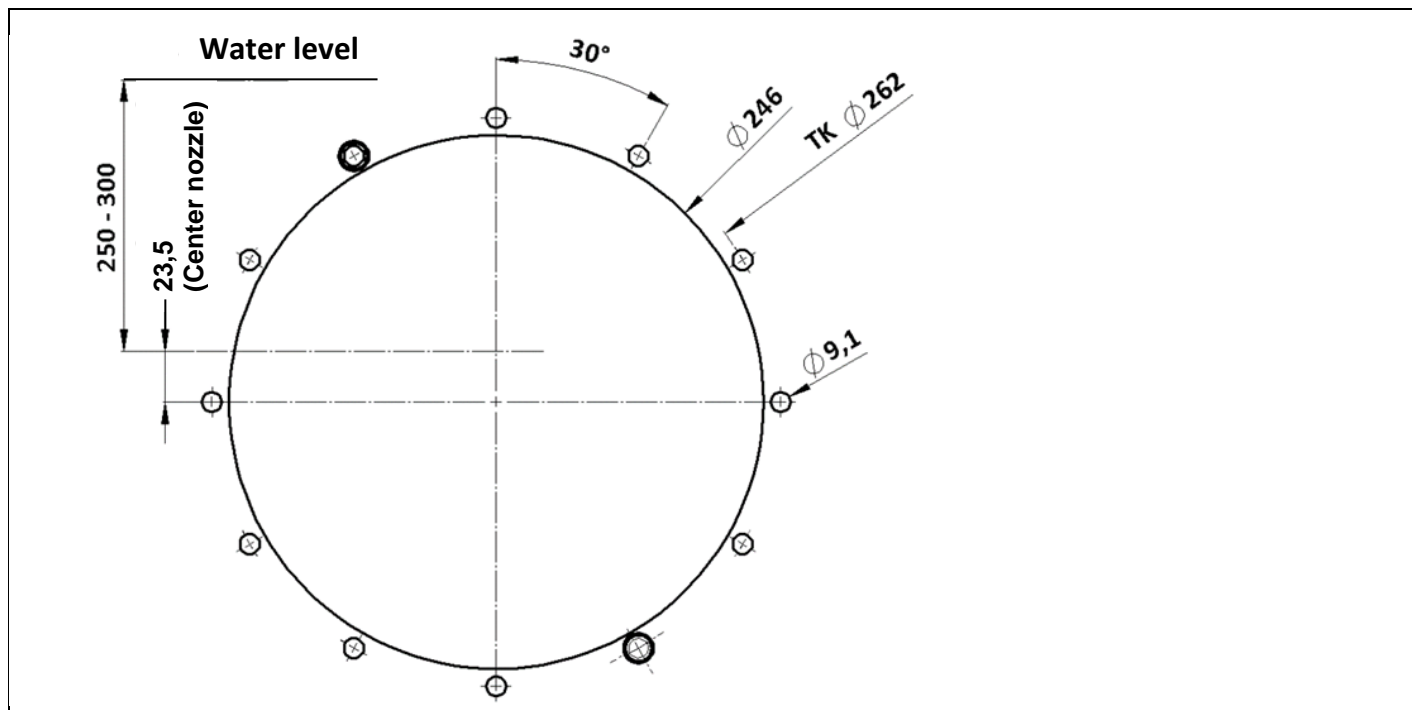

Fig. 10 Hole pattern and detail of pool – preassembled pool

5.6. Preparation for installation of stainless steel pool

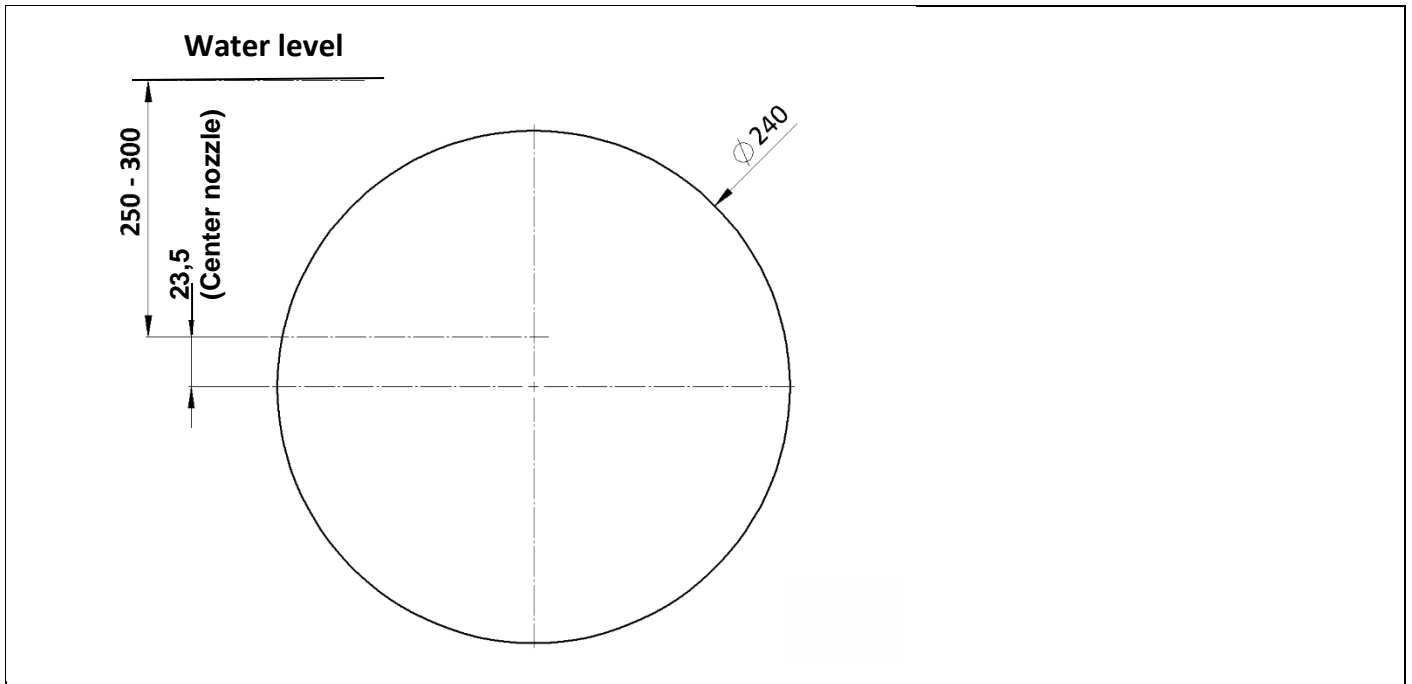

Fig. 11 Detail of stainless steel pool

5.7. Concrete pool (tiled – with or without liquid seal, liner)

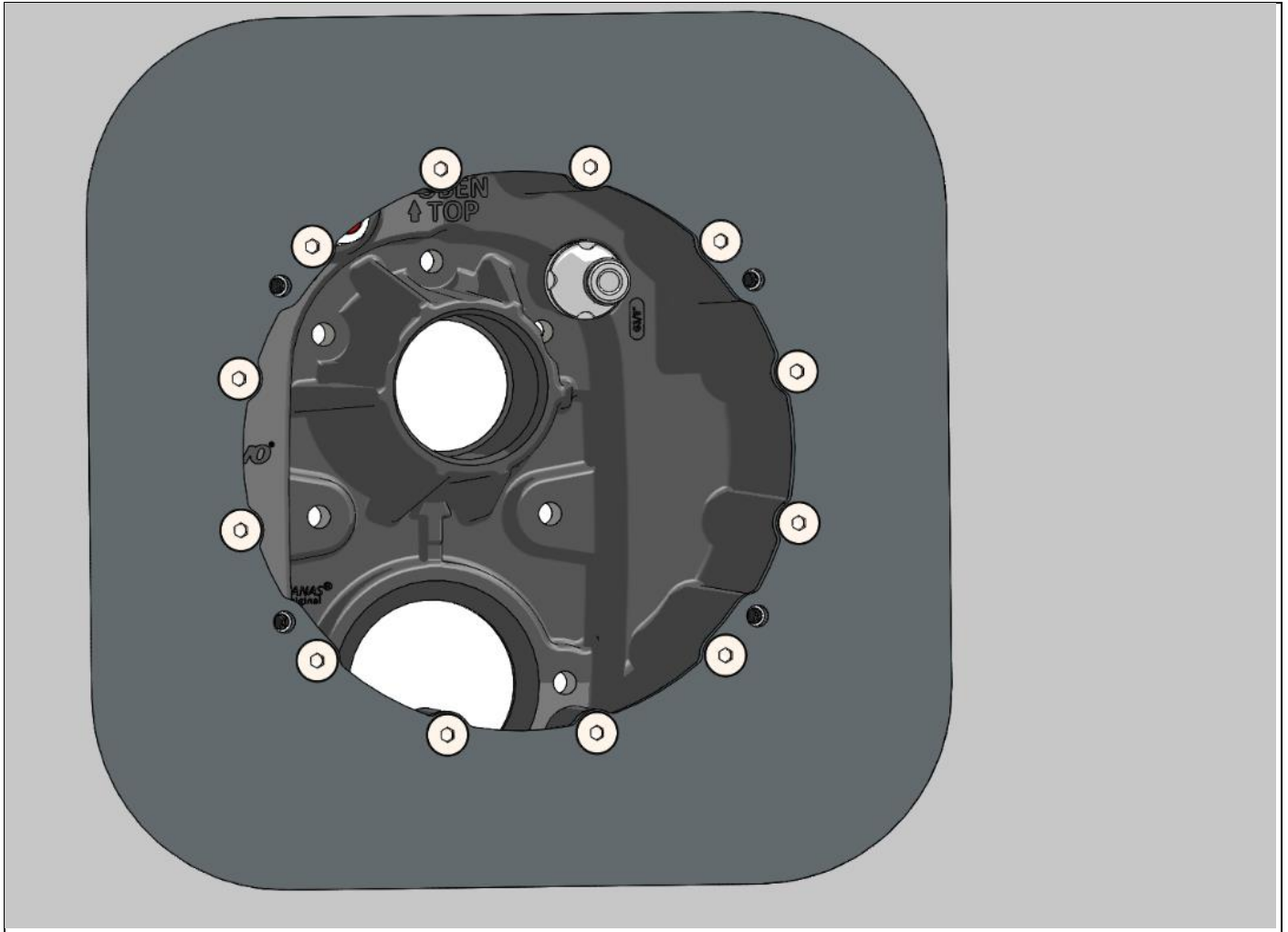

Fig. 12 Example illustration: Brush-applied sealant design (liquid seal)

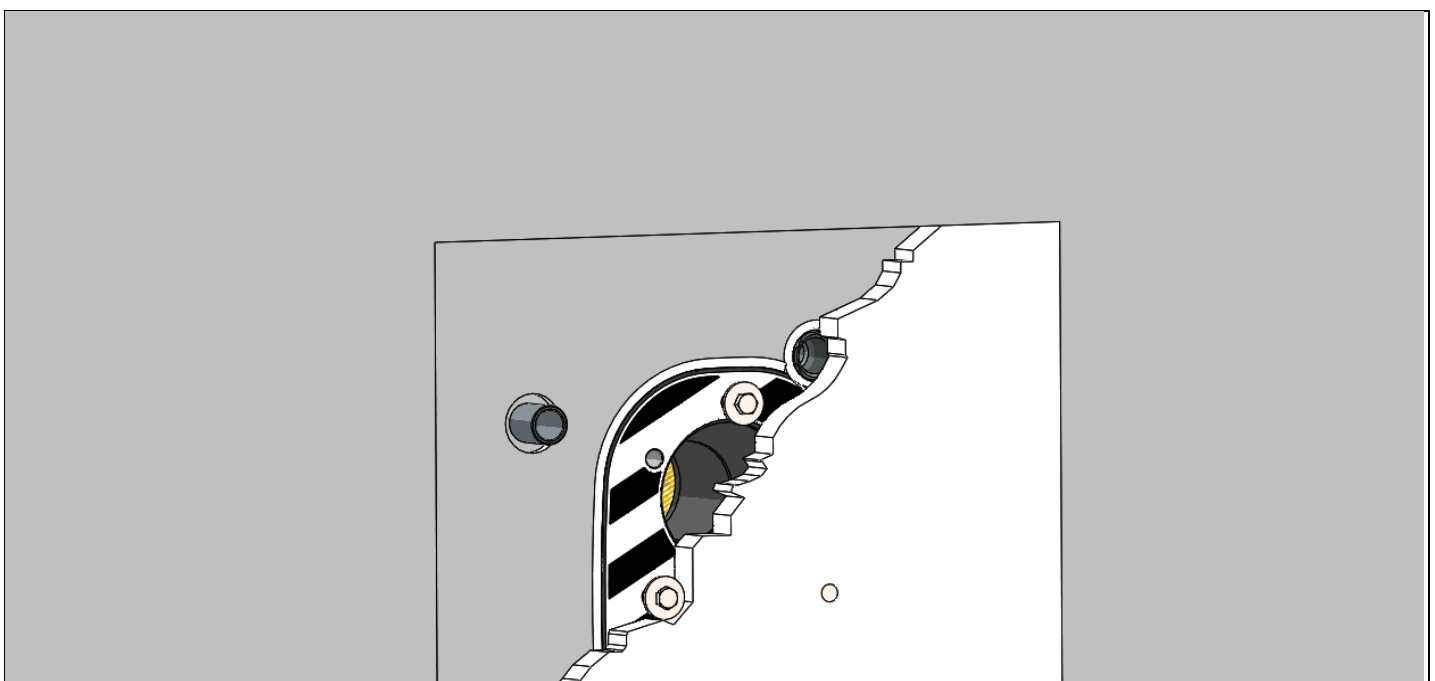

Fig. 13 Removing the rear polystyrene formwork, but not the protective sticker yet.

5.8. Preassembled pool

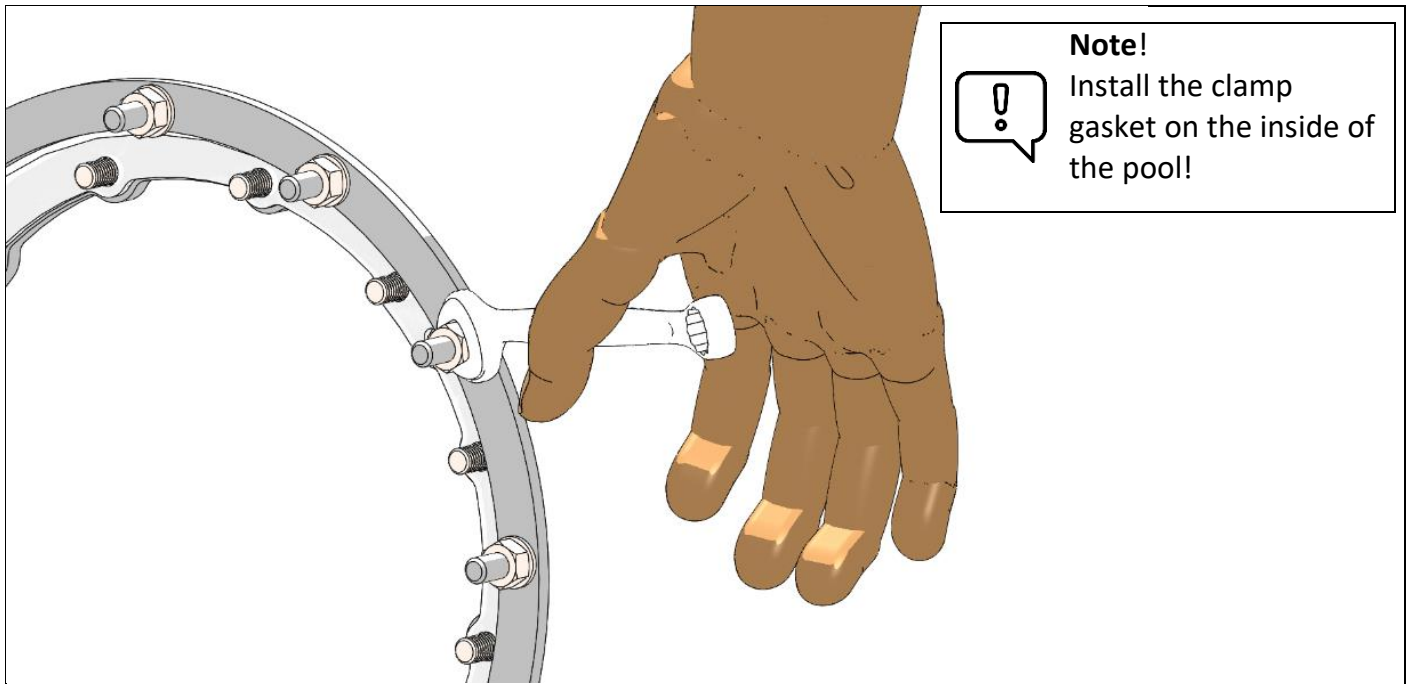

Fig. 14 Mounting the clamp ring

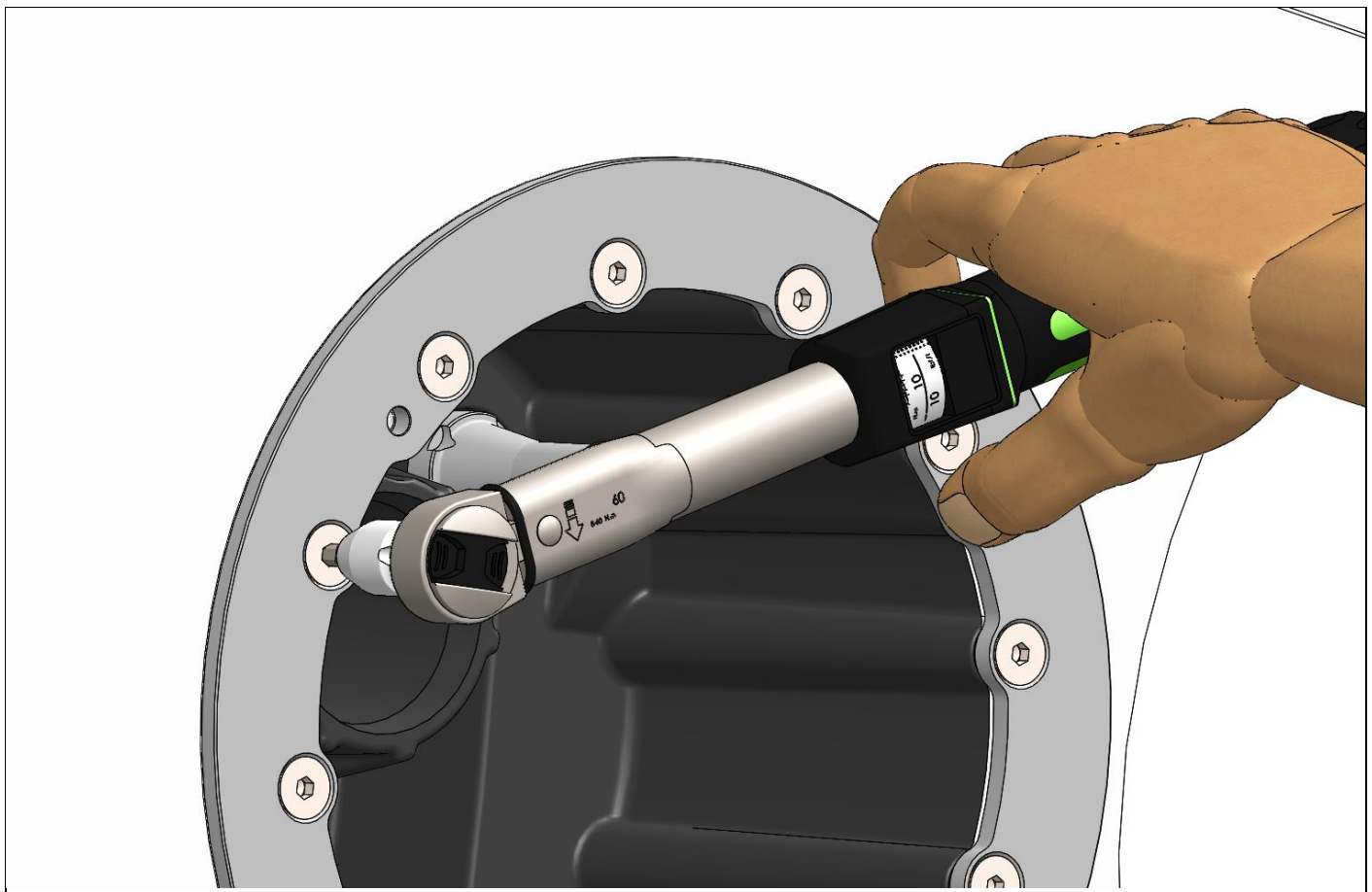

Fig. 15 Mounting the installation housing (observe tightening torque – 15Nm)

5.9. Stainless steel pool

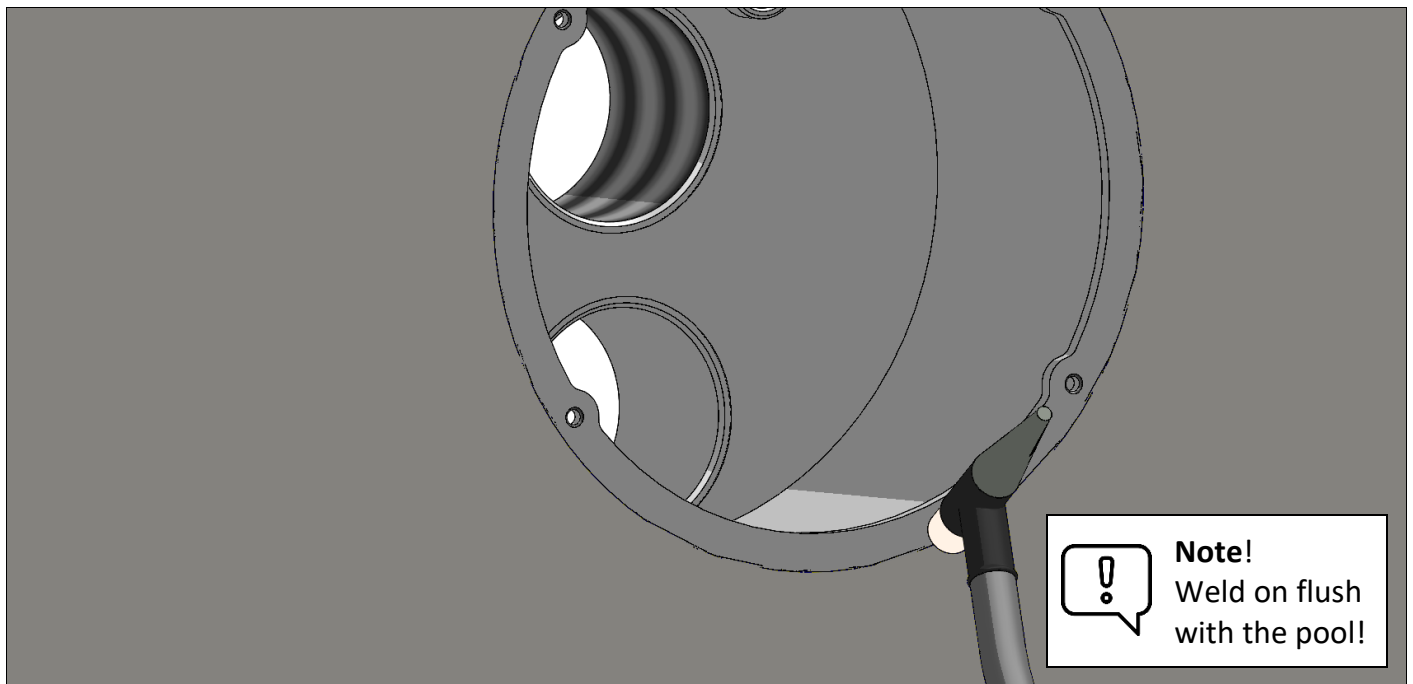

Fig. 16

5.10. Pipeline adapter / pump connection

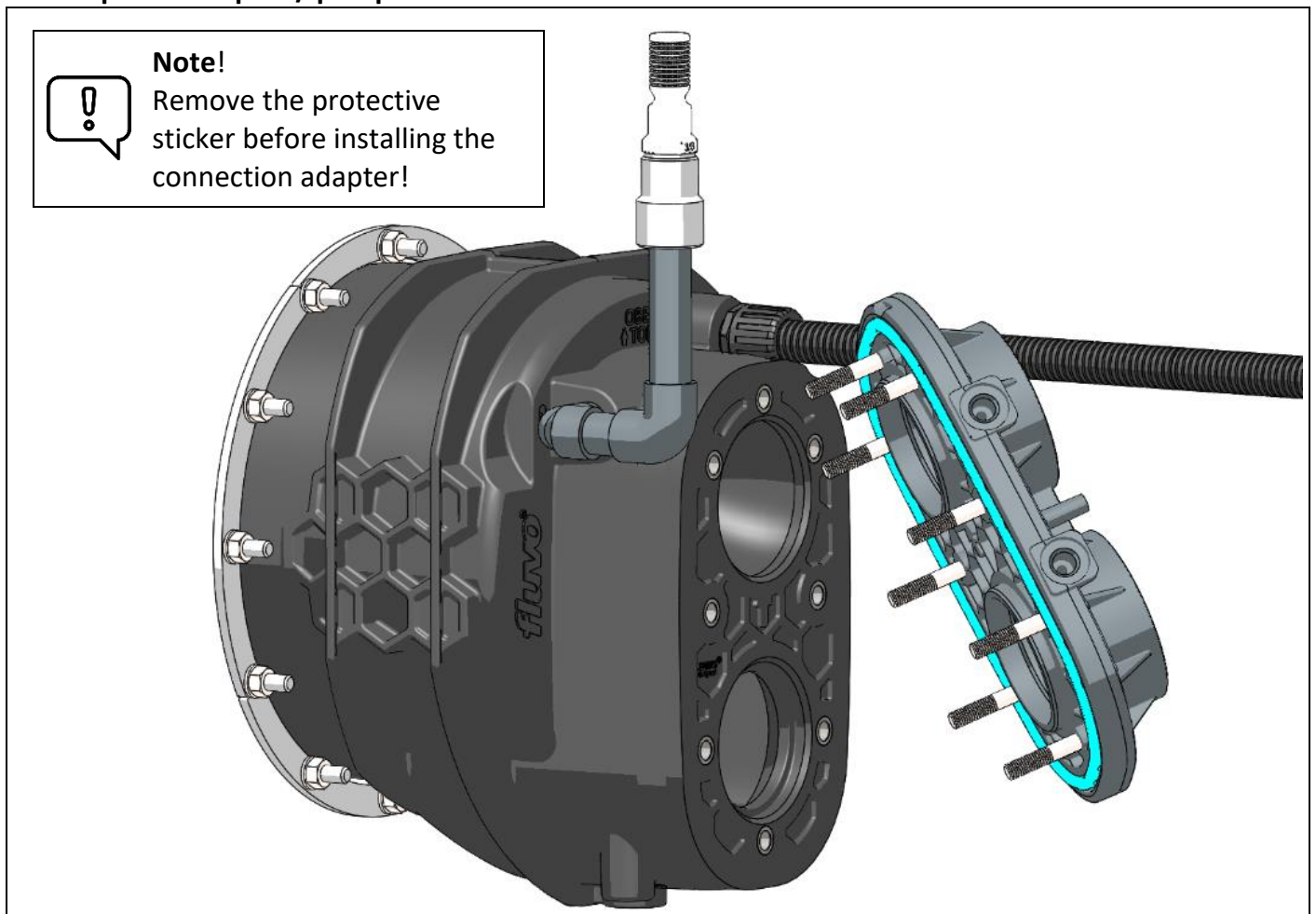

Fig. 17 Put on pipe connection adapter incl. moulded seal (part of the pump kit)

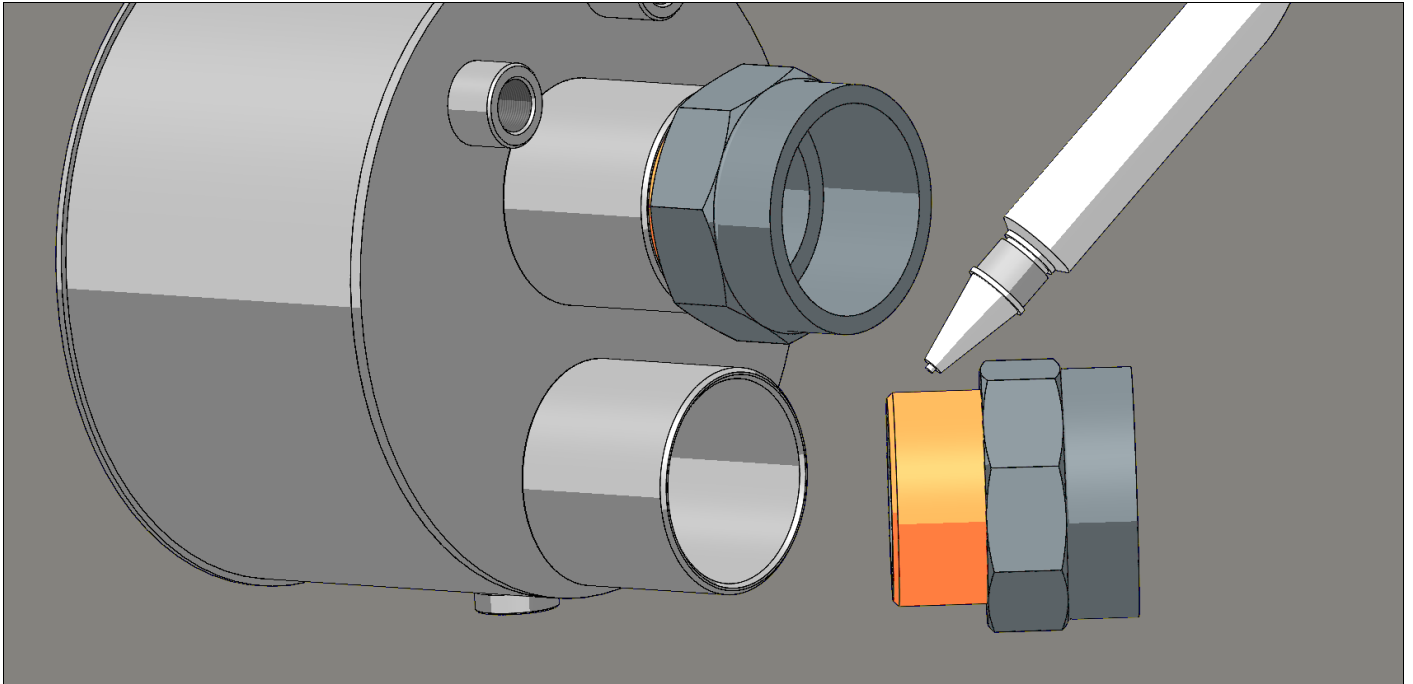

Fig. 18



Note!

When installing the plastic threads, care must be taken to install them tightly with a liquid pipe or thread sealant (e.g. LOCTITE 5331)

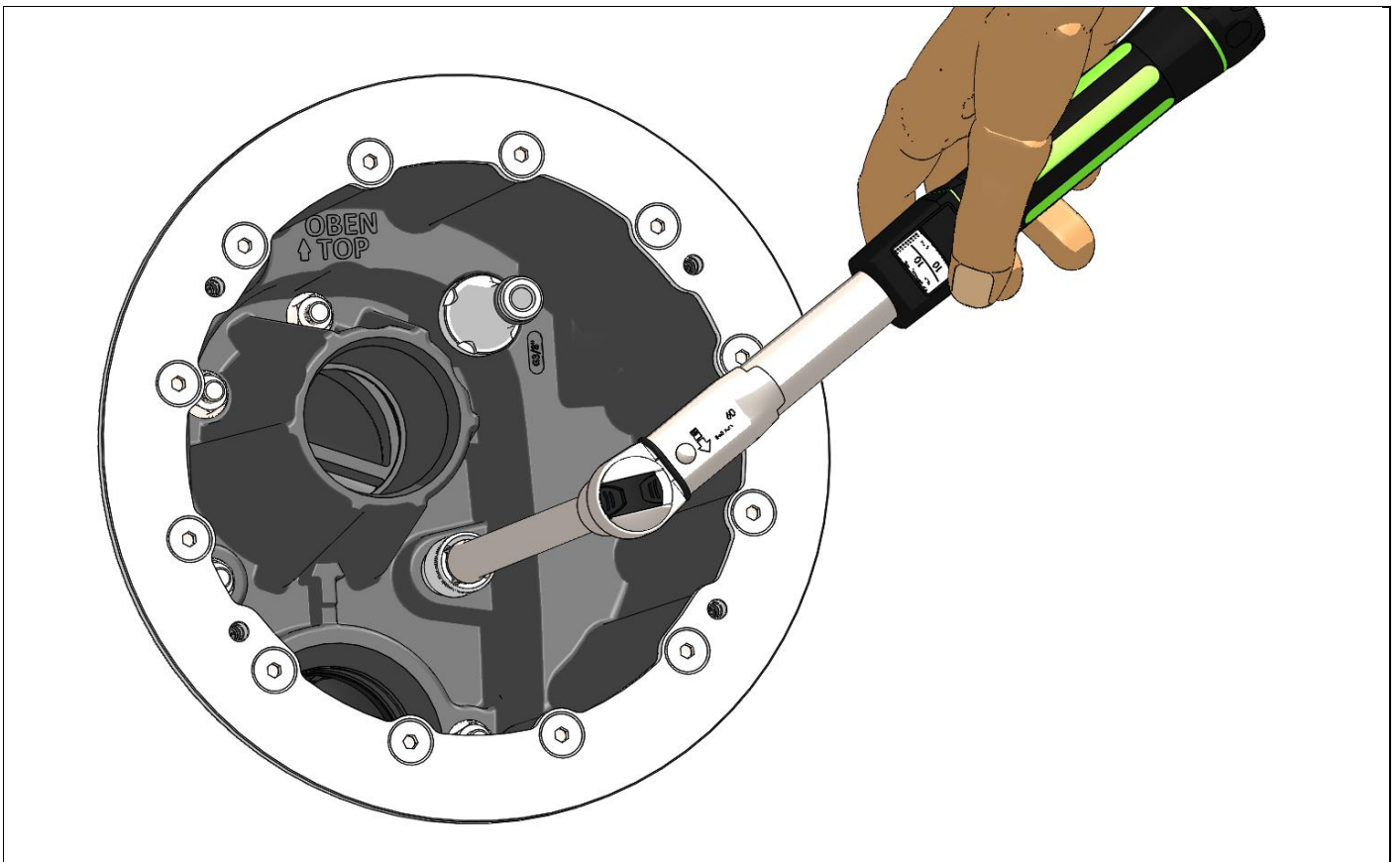

Fig. 19 Tightening the hexagon nuts of the connection adapter to 15Nm.

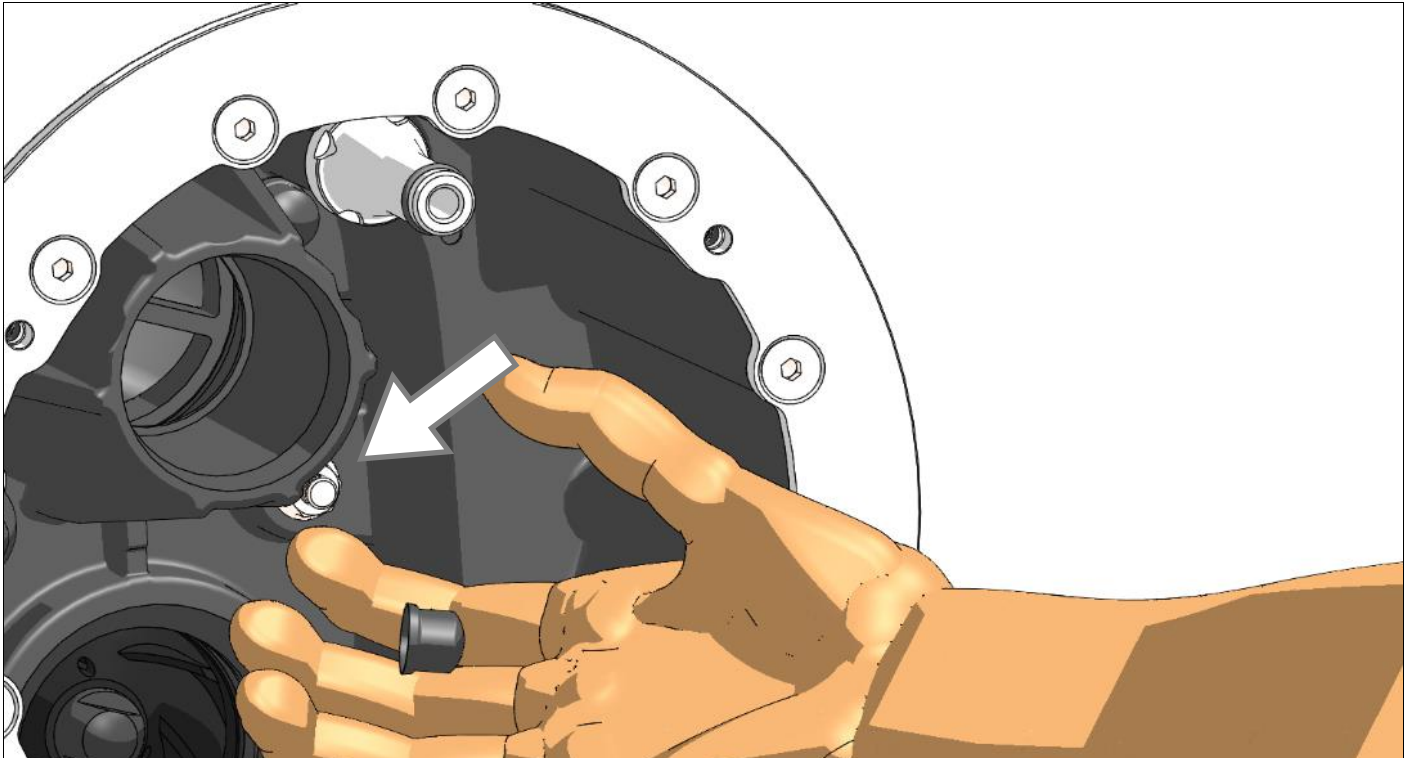

Fig. 20 Pressing the protective caps onto the hexagon nuts!

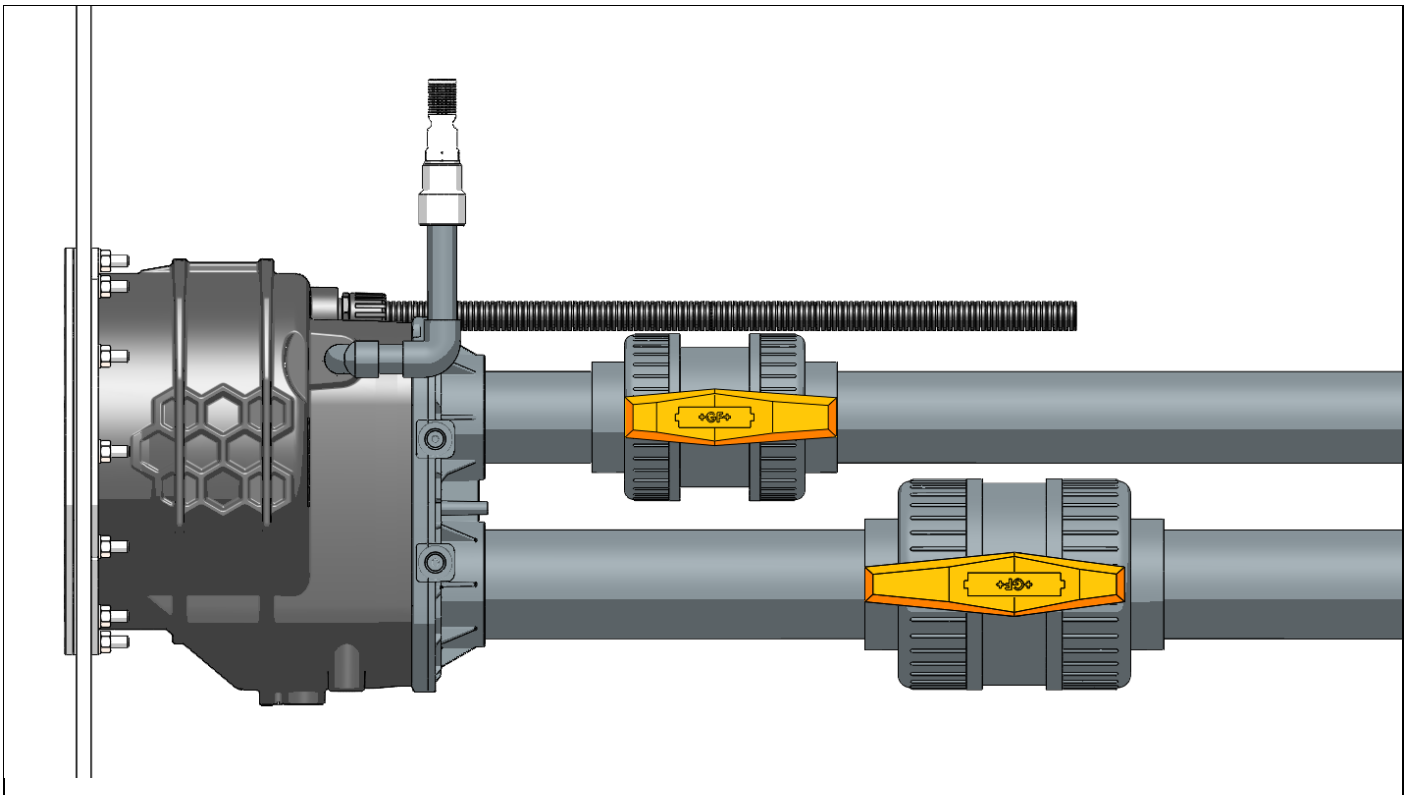

Fig. 21 Pipework – isolated design (example illustration)

5.11. Retro-fitting

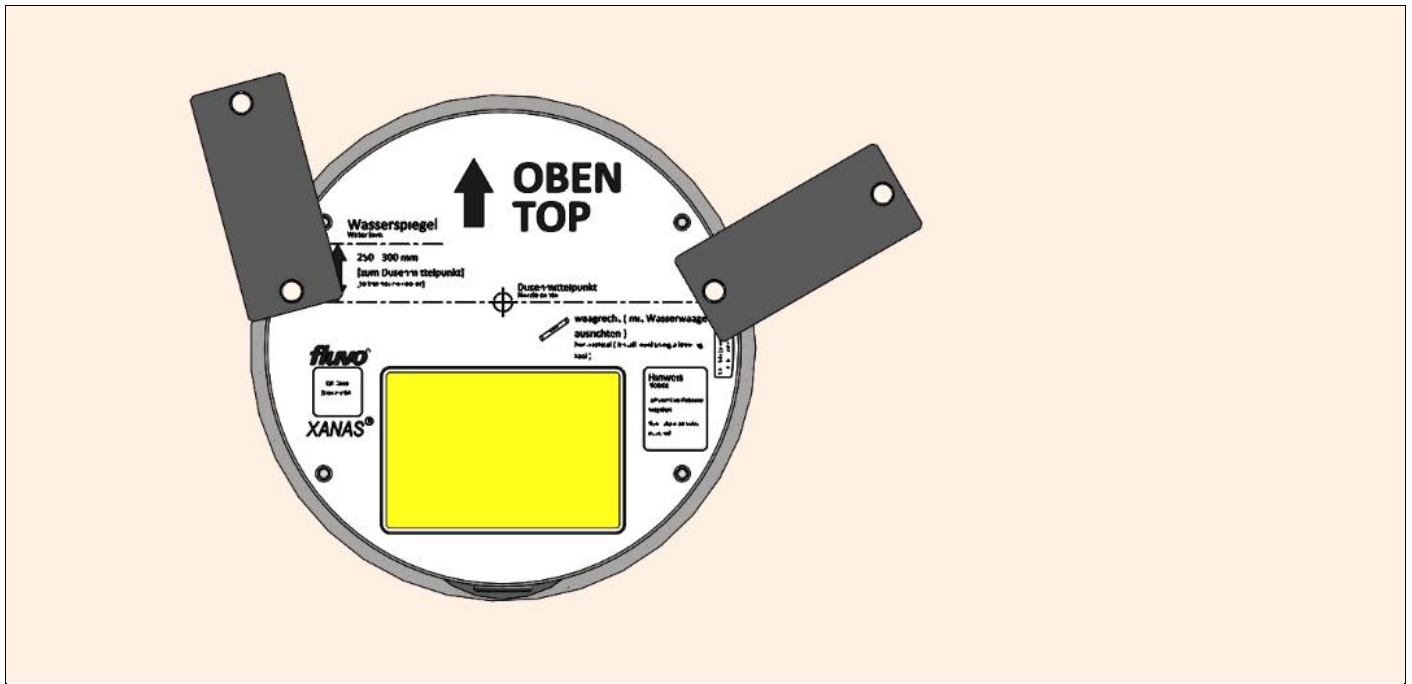

Fig. 22



Note!

A version for retro-fitting is available – article number 98574 – For details see installation instructions 72311

6. Assembly kit installation instructions

6.1. Assembly (general)

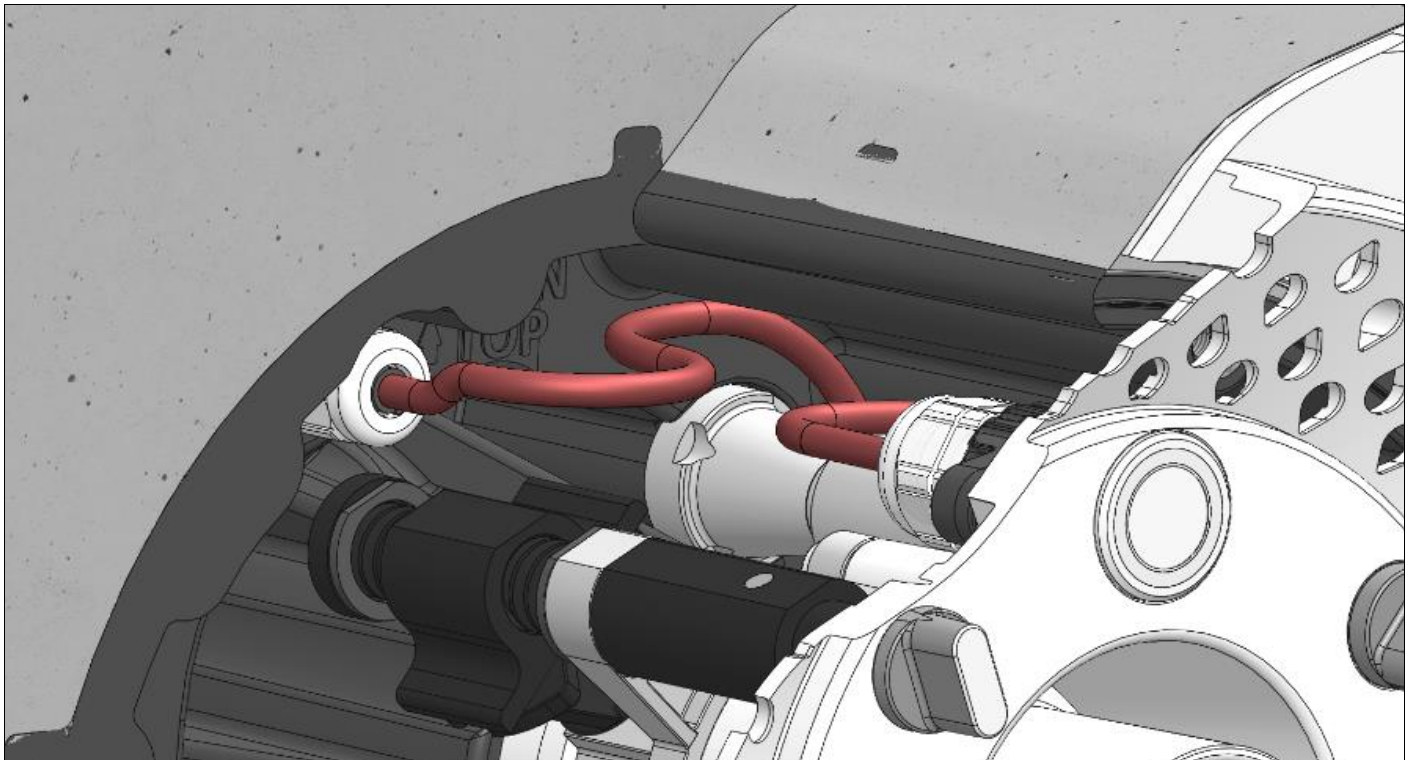

Fig. 23 Pulling the cable (sensor button) through the cable screw connector and tighten.



Note!

If possible, lay the cable in the upper right part of the installation housing!

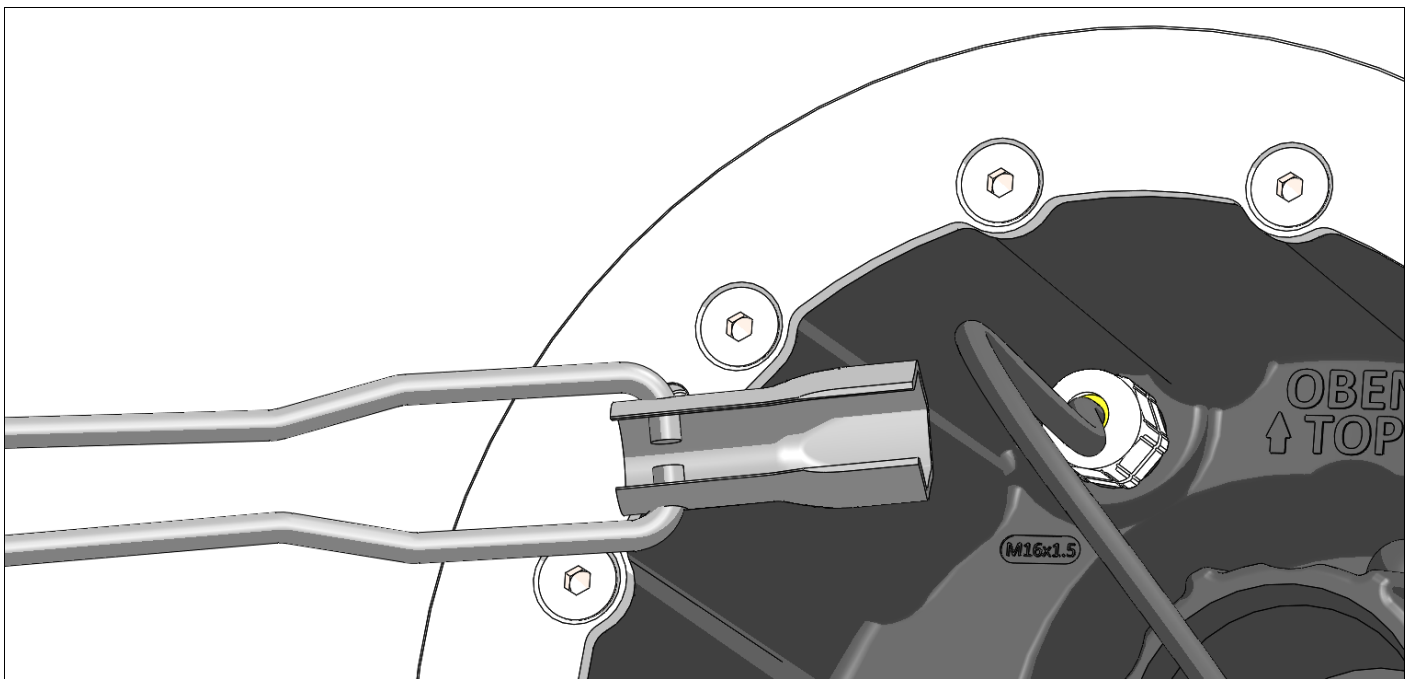

Fig. 24 Using the supplied tool for easy installation.

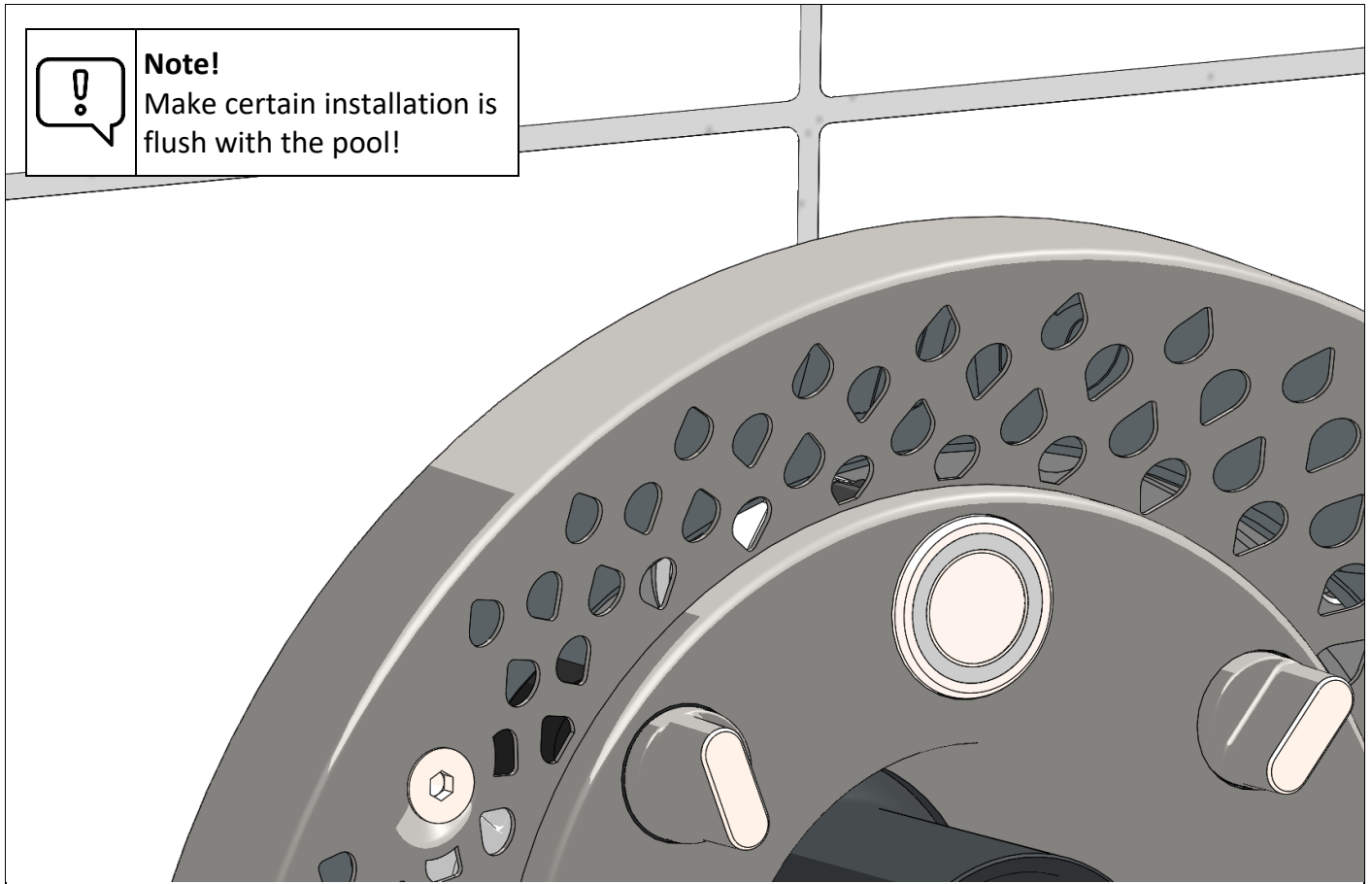

Fig. 25

6.2. Assembly of concrete pool (tiled - with or without liquid seal)



Fig. 26 Attach the nozzle head (note position of the pressure connection and air connection) and screw it on.

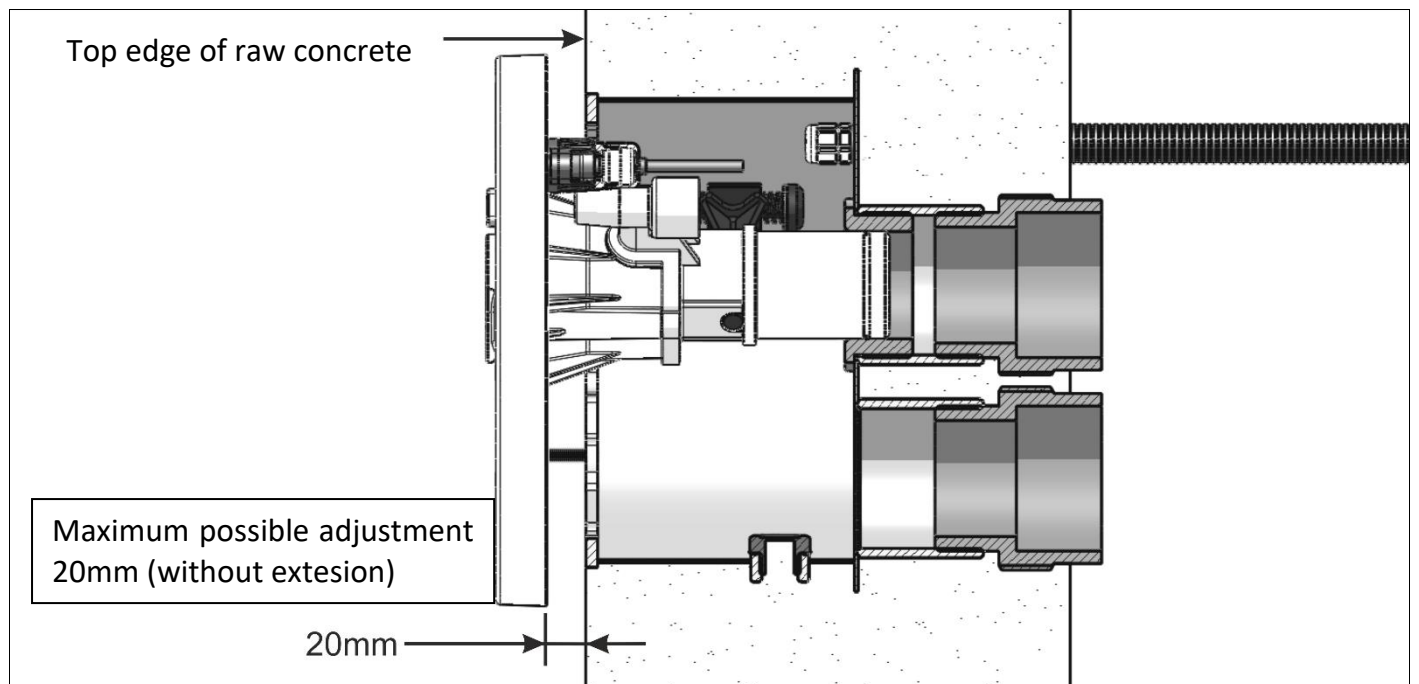

Fig. 27 Example of installation kit in stainless steel design



Note!

Suitable extensions are available for adjustment of more than 20mm.

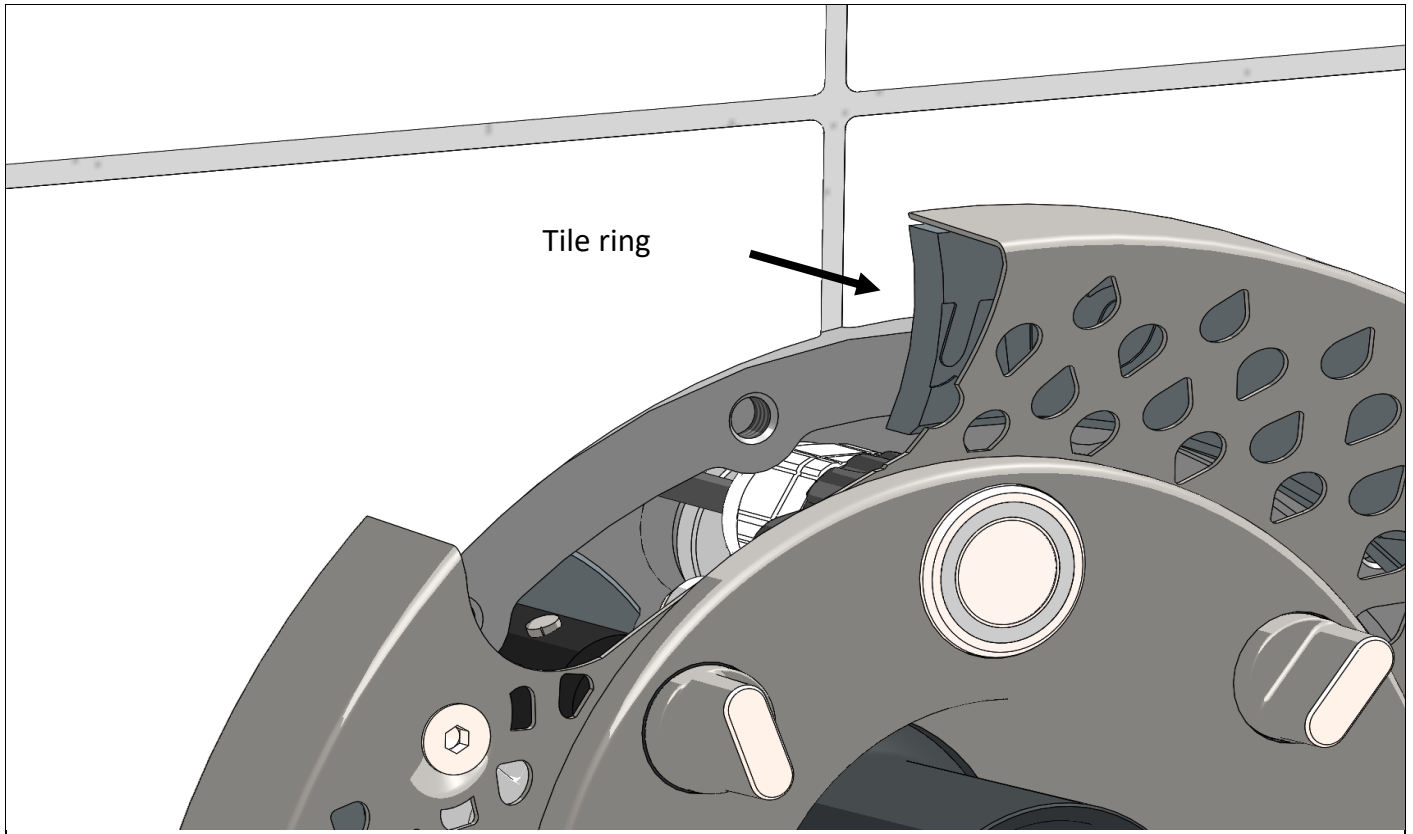

Fig. 28 Detail: Tile ring (stainless steel design only)

6.3. Concrete pool (liner)

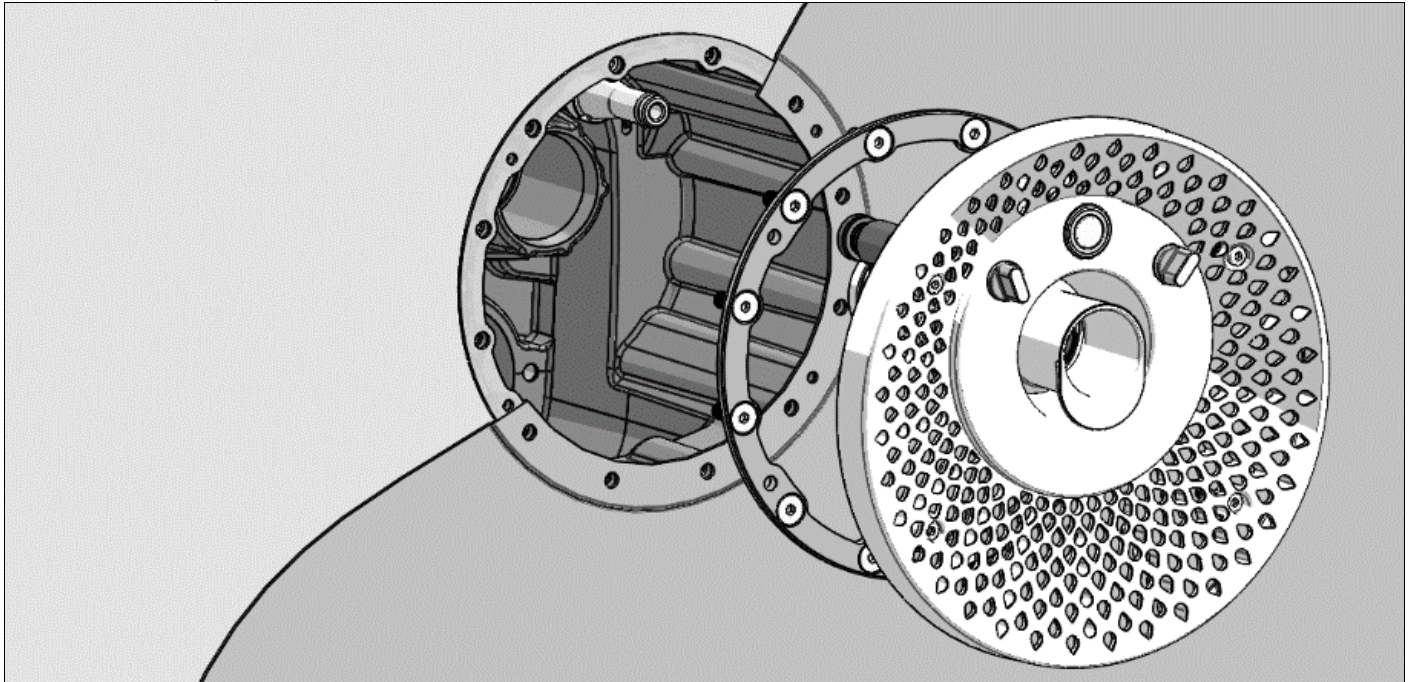

Fig. 29



Note!

Installation sequence: Installation housing / seal / liner / clamping ring / nozzle head

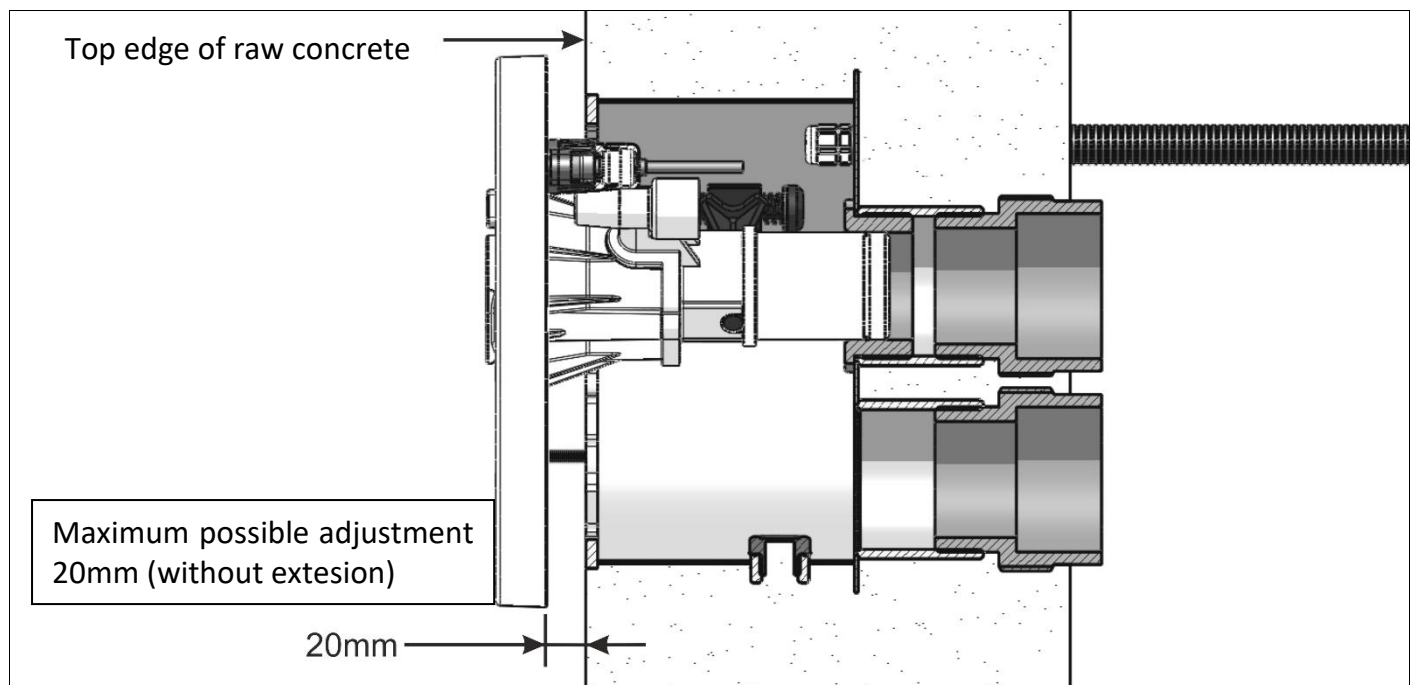

Fig. 30 Example of installation kit in stainless steel design



Note!

Suitable extensions are available for adjustment of more than 20mm.

6.4. Preassembled pool

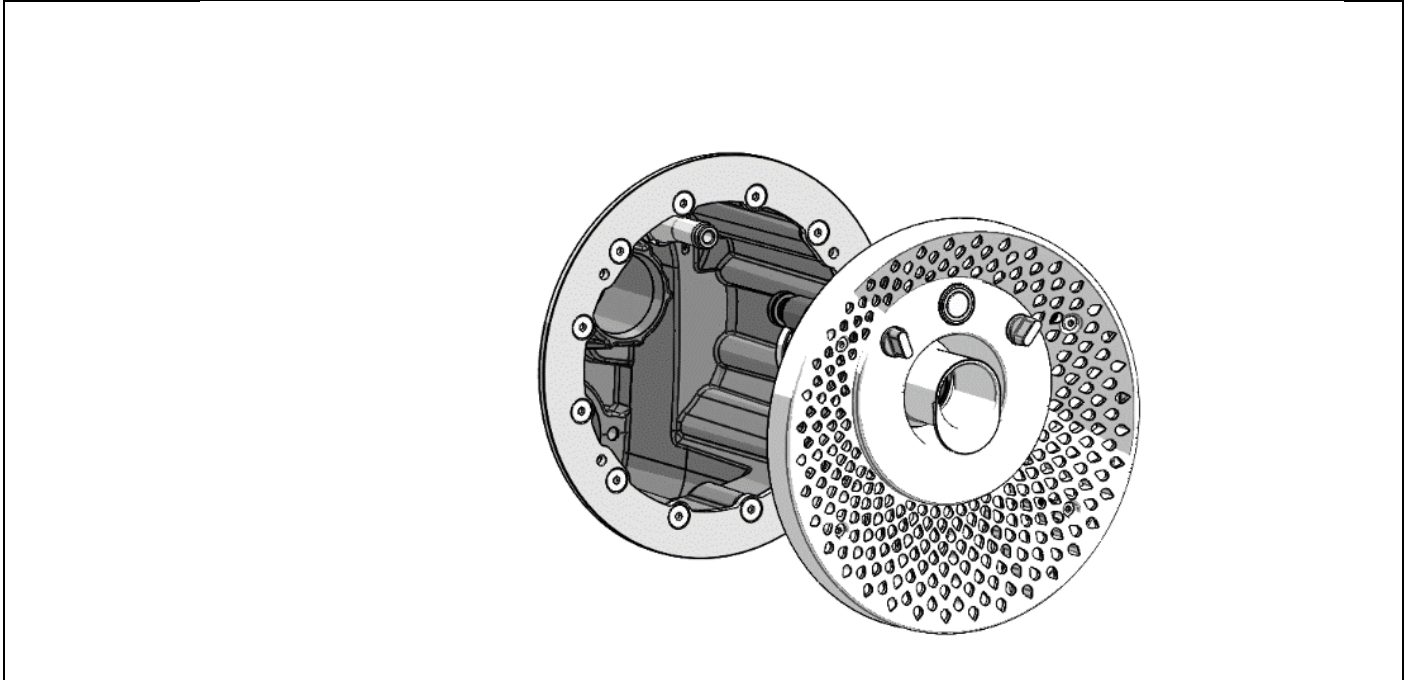

Fig. 31 Insert the nozzle head and screw it on.

6.5. Stainless steel pool



Fig. 32 Insert the nozzle head and screw it on (illustration shows stainless steel design with tile or spacing ring).

7. operation

7.1. Switching On/ Off

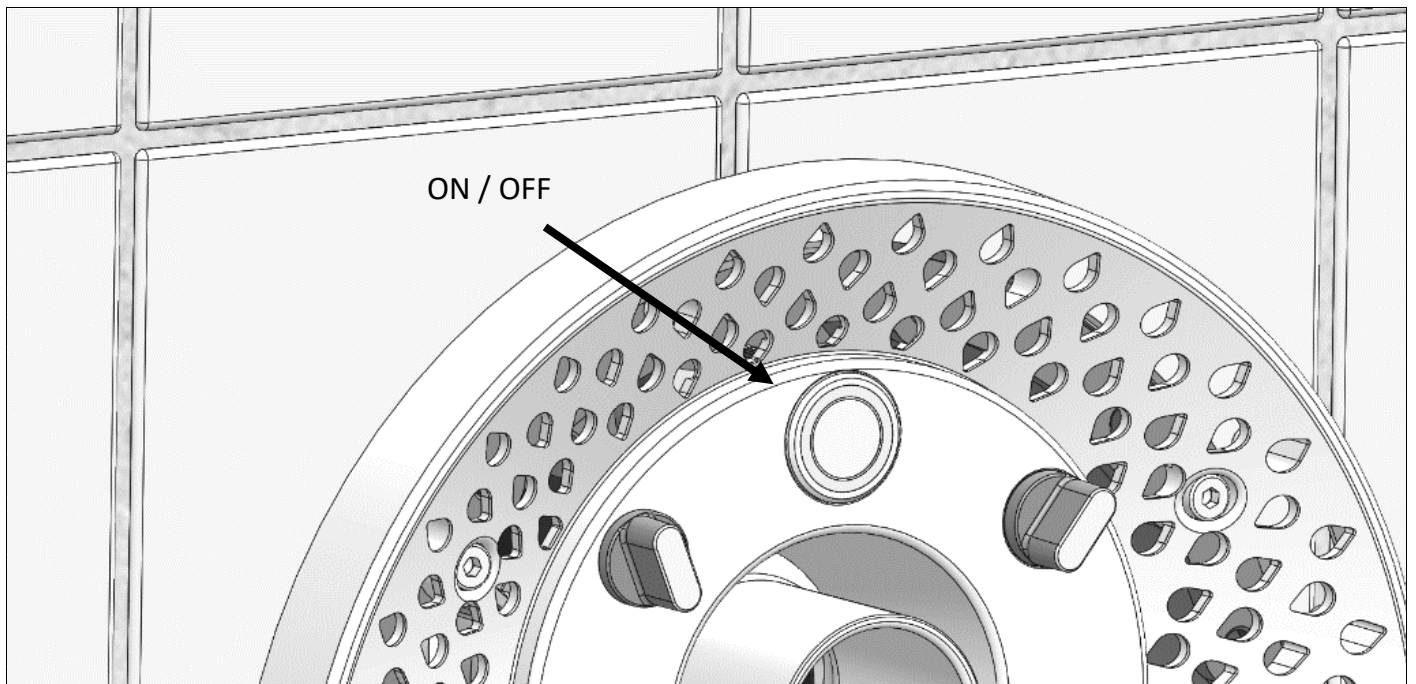

Fig. 33

Pressing the ON/OFF button turns the system on or off. The button is always lit and flashes to provide visual feedback.

7.2. Regulating the intensity

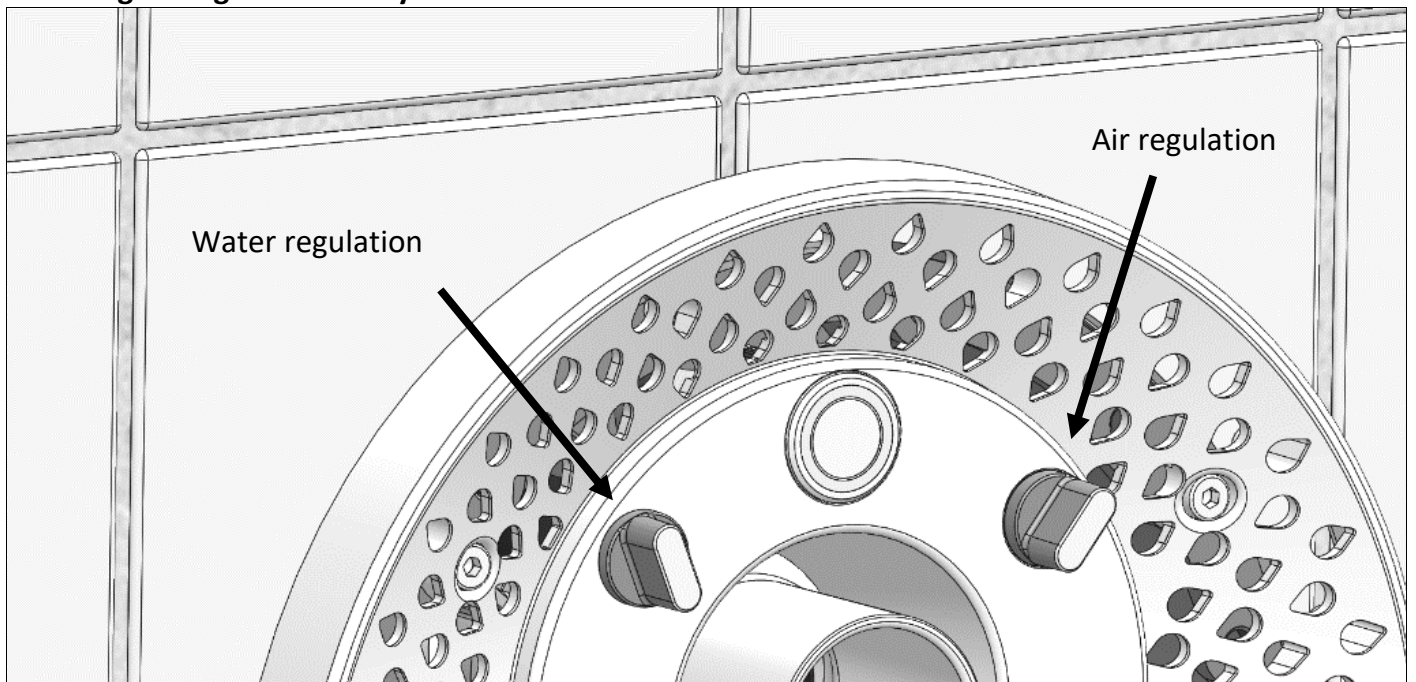

Fig. 34 Manual control (twist grips for water quantity and air supply)

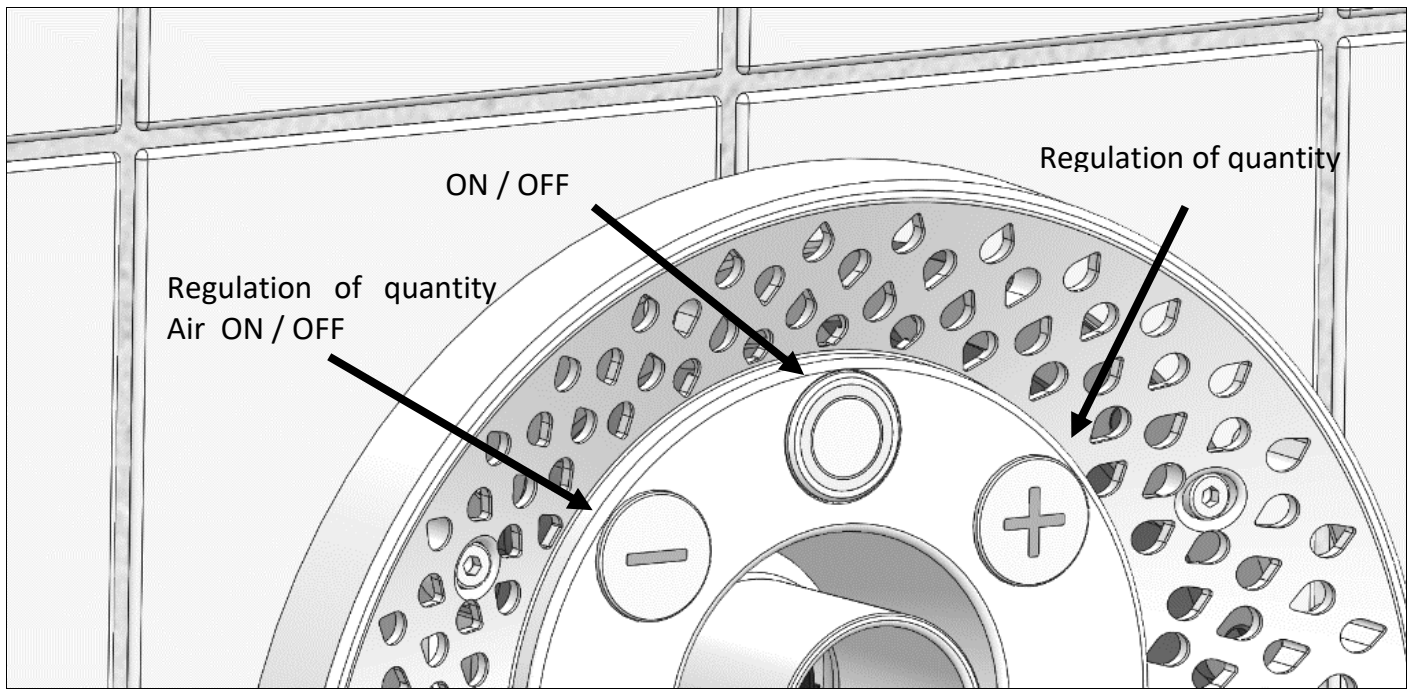



Fig. 35 Sensor-controlled control

Pressing the ON/OFF button turns the system on or off. The button is always lit and flashes to provide visual feedback.

Pressing the + / - keys increases or reduces the corresponding amount. The lit sensor button flashes to provide visual feedback. When the maximum or minimum quantity is reached, the button flashes several times to provide visual feedback.

Air ON/ OFF

If an air valve is installed, the Quantity  button can be pressed twice quickly to turn the air supply on or off.

8. Troubleshooting

	<p>Attention! All repairs and alterations to the device must only be performed by specialists qualified according to accident protection regulations. Otherwise the user / operating company may be subject to damage (accidents)</p>
---	--

The malfunctions listed in the table are the most common causes of improper functionality. If the measures described there do not resolve the problem, hire a specialist to determine the cause of your specific case of improper functionality.

Malfunction	Possible reason	Remedy
1. Pump runs very loud and produces little output	Wrong direction of rotation for the motor	Reverse the polarity of the motor in the terminal box, thereby switching the direction of rotation
	Motor fan scrapes against the fan hood	Correctly secure the fan hood
2. Pump starts up slowly and only with difficulty	A current-conducting phase is missing	Check the supply lines and fuses
3. The fuses are blown immediately at power-up	Wrong fuses or fast acting fuses	Install delayed fuses with the correct amperage rating
4. Motor protection switch is triggered	Note star / delta circuit	Correct star / delta and check direction of rotation.
5. The centrifugal pump cannot be turned on from the swimming pool	- Fuses / power supply - Motor protection switch	Check whether the centrifugal pump can be switched from the control box.
6. Air valve has a leak	dirty	During operation, unscrew the air valve and replace if necessary Note: The air valve must be positioned above the water level.

9. Taking out of operation / winter storage



Attention! Risk of damage!

If there is a risk of freezing the system must be winterproofed. Follow the recommendations below to do this.

9.1. Draining the pool



Important note!

Make certain when the pool is emptied that no direct sunlight strikes the plastic elements. Cover immediately!

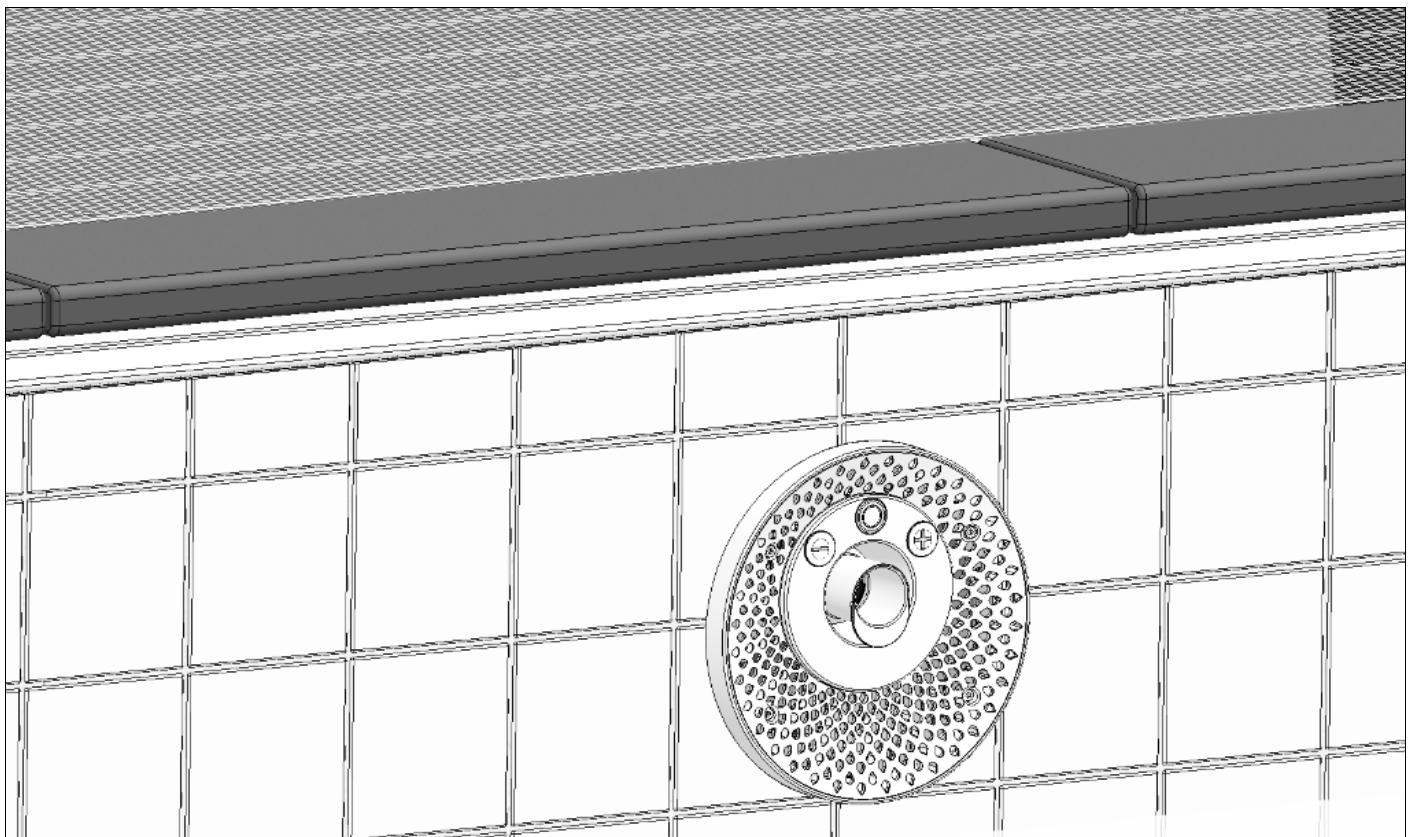

Fig. 36



Attention! Risk of damage!

Make certain there is sufficient protection against freezing for your entire swimming pool and its equipment. Follow the pool manufacturer's instructions!

- Drain the water completely from the pool,
- or drain water down to at least 15-20 cm below the nozzle head.
- Turn off the main switch!
- Remove the nozzle head (see next page)

9.2. Winter storage of the nozzle head

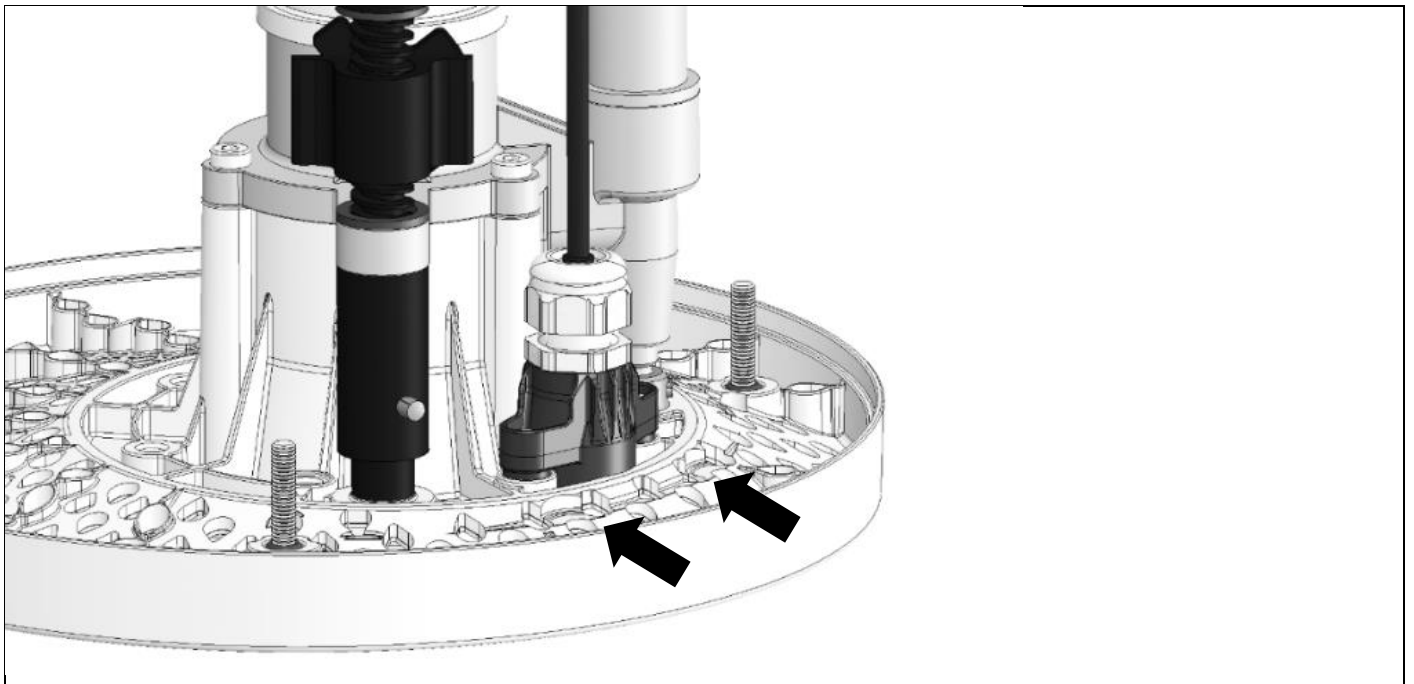

Fig. 37

**Note!**

Unscrew the sensor button (2xM6) and keep it securely in the installation housing, then mount the (separately available) dummy cover.

9.3. Draining the Pump

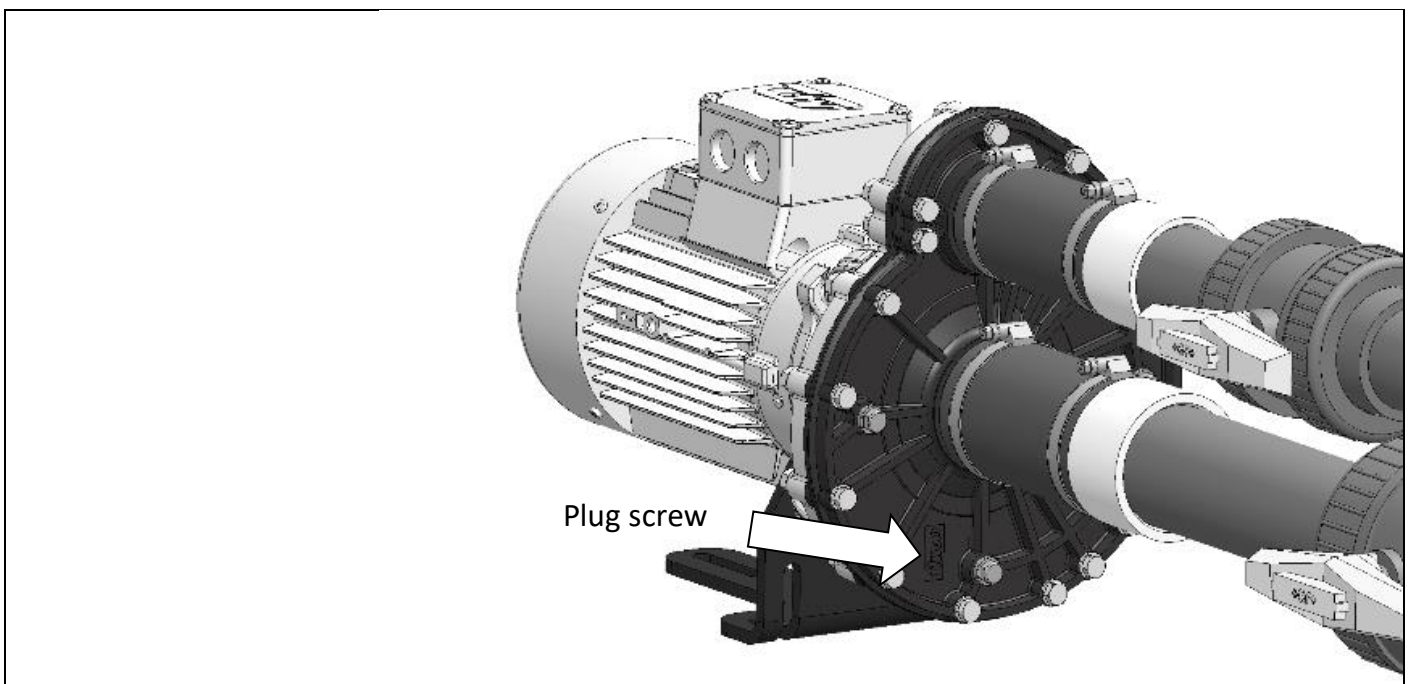

Fig. 38

Close the gate valve, ball valve or similar mechanism. Then unscrew the plug screw and drain the water.



Attention! Risk of damage!

Make certain all the water runs out! If there is a pipeline system leading to the pump, drain it as well!

Then screw the plug screw back in with a new O-ring. When placing the system in operation again, follow the instructions in the relevant Operator's Manual (27220).

10. Maintenance and repairs

10.1. General information

All work on the counter-current system must only be performed when the pump has been drained and the control unit and pump motor are electrically de-energised and protected against being energised again.

10.2. Maintenance

- The counter-current system itself is largely maintenance-free.
- Be careful to keep all the parts of the counter-current system clean.
- The seals on the motor axle must be checked at regular intervals (at regular intervals once a year) by a specialist. If necessary they must be replaced with original replacement seals.

10.3. Repairs

- Follow the instructions for assembly and commissioning with all repairs to the counter-current system.
- Use only original spare parts to repair the counter-current system.

11. Exploded drawings – overview of parts/ spare

11.1. Installation kit PU

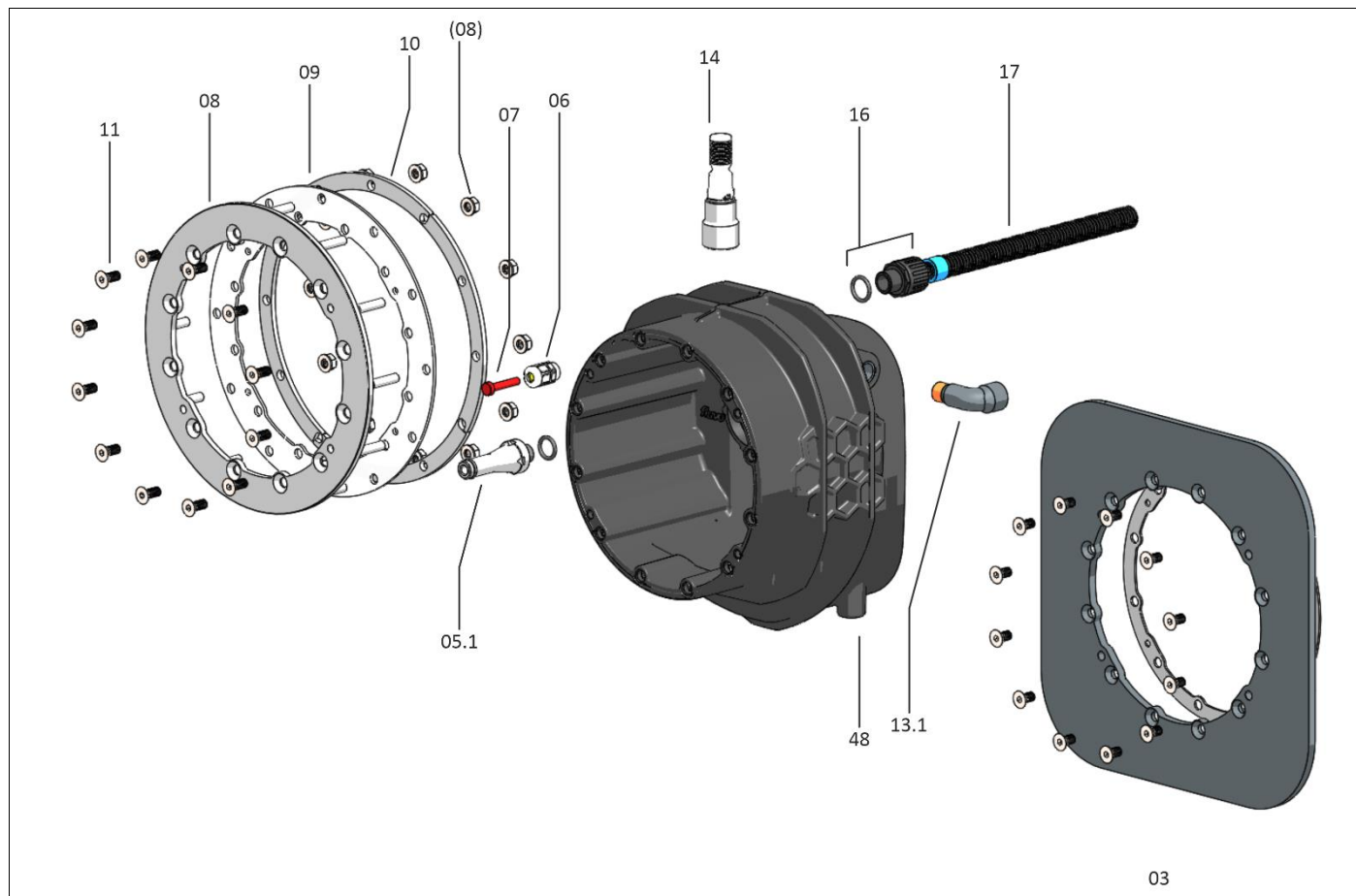

Fig. 39

11.2. Installation kit INOX

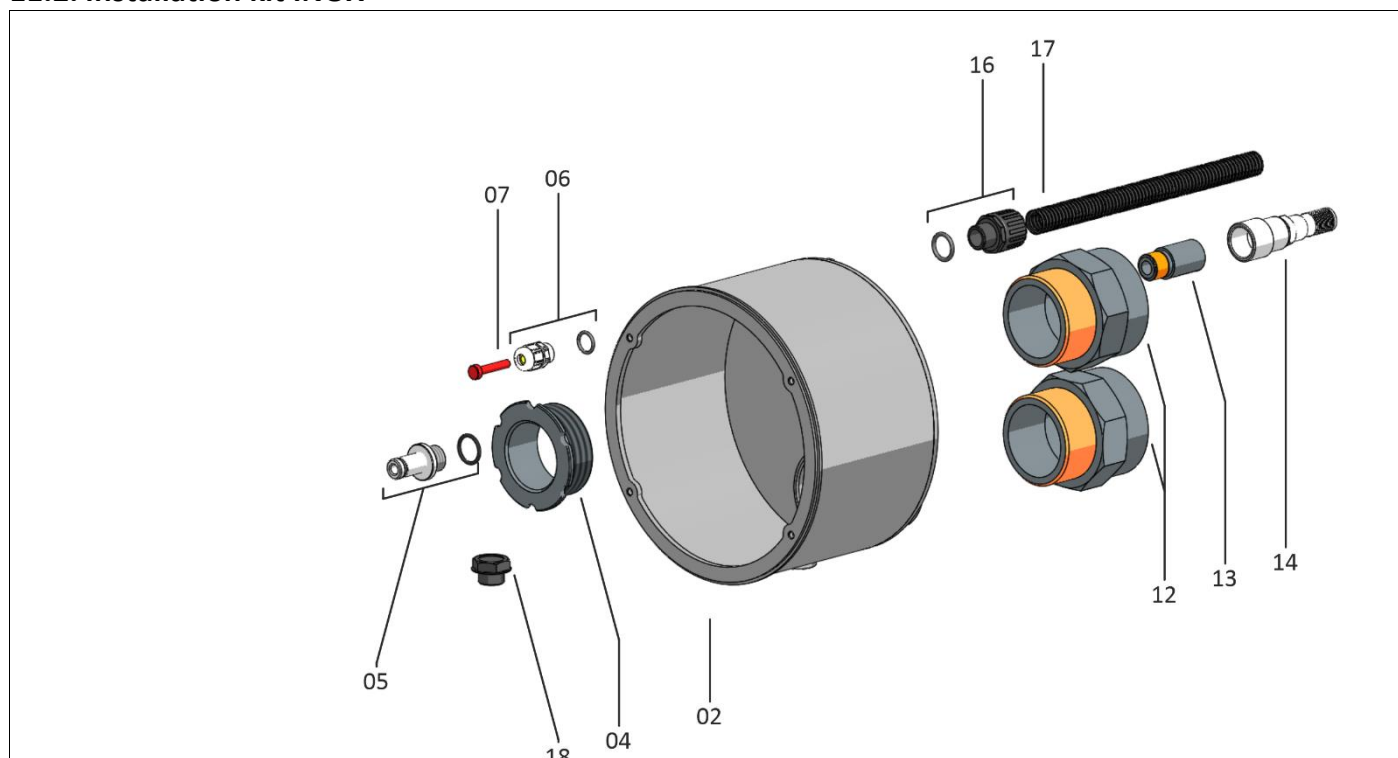

Fig. 40

11.3. Assembly kit ABS – manual control

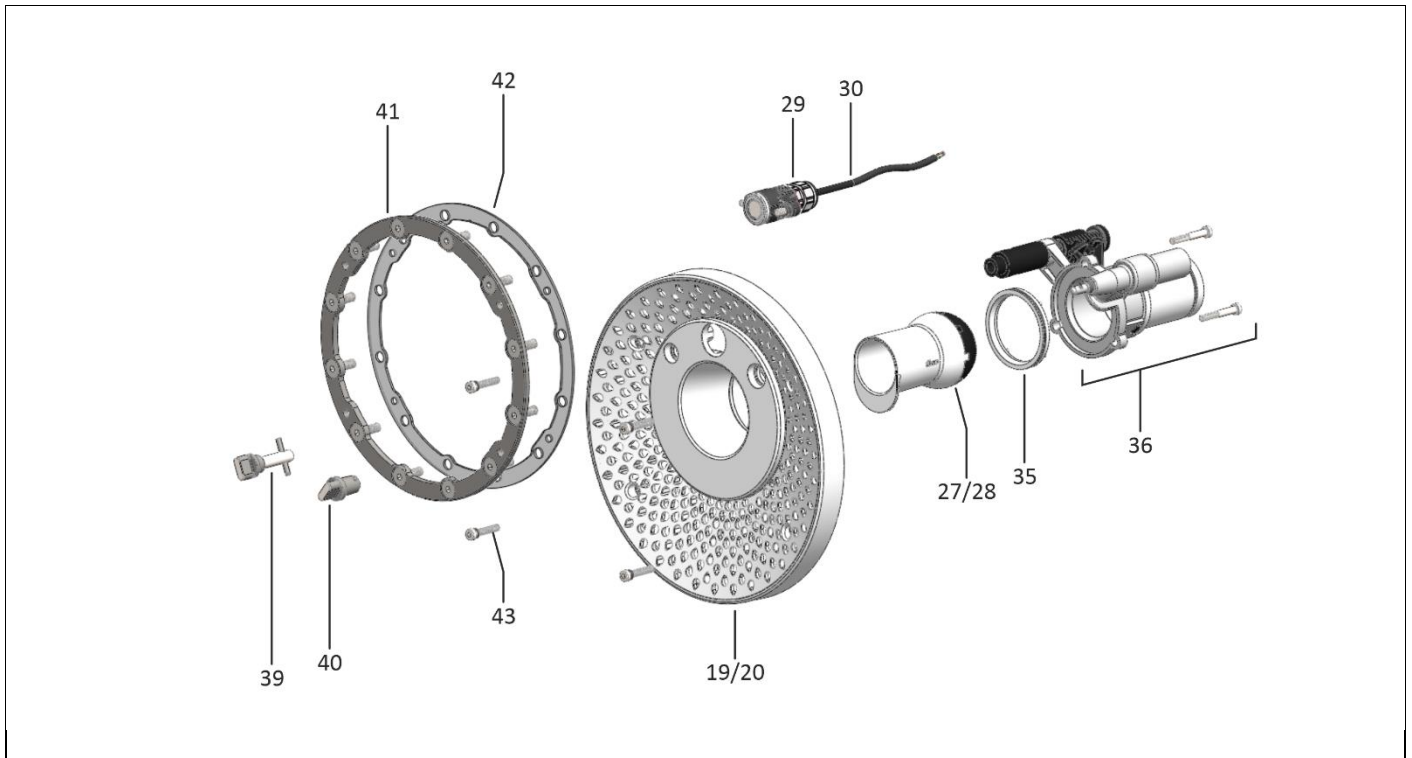

Fig. 41

11.4. Assembly kit INOX – manual control

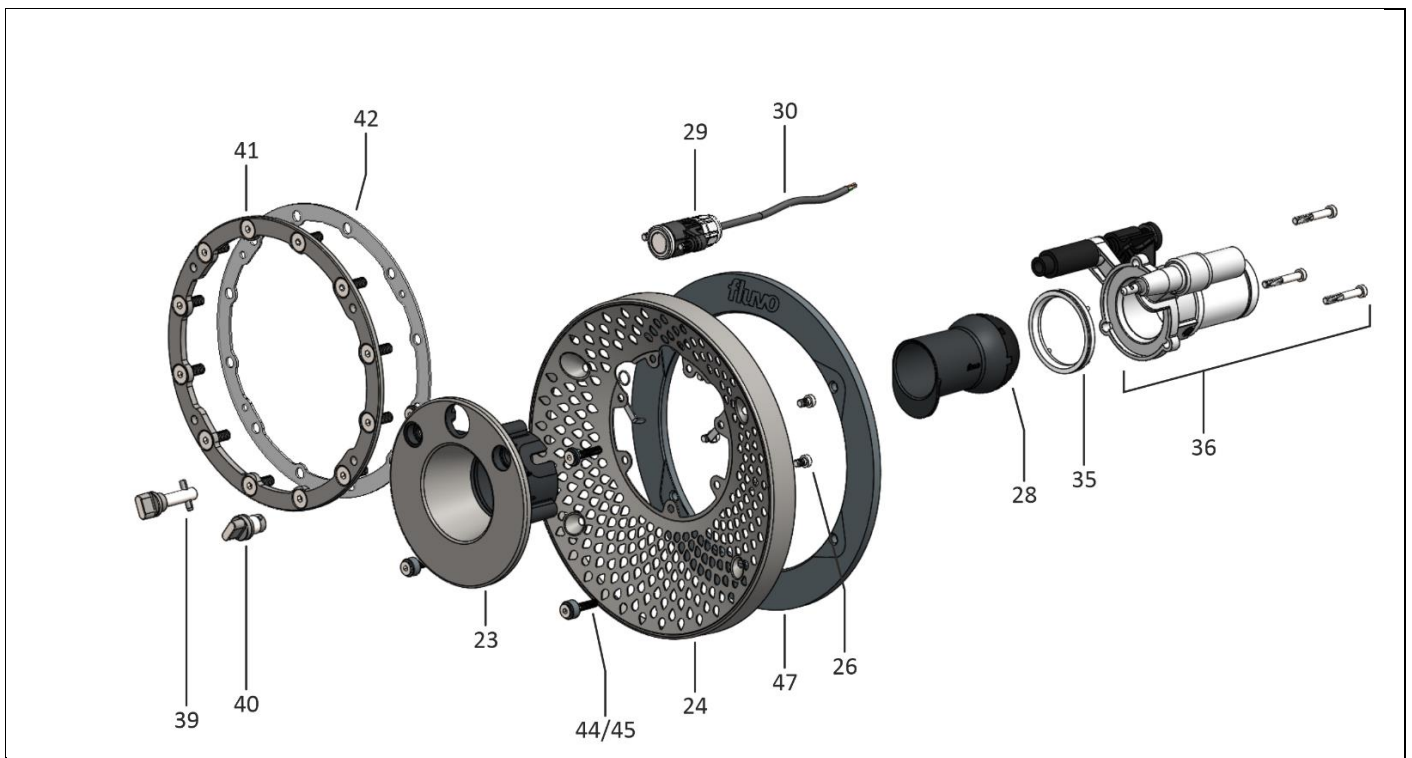

Fig. 42

11.5. Assembly kit ABS – sensor control

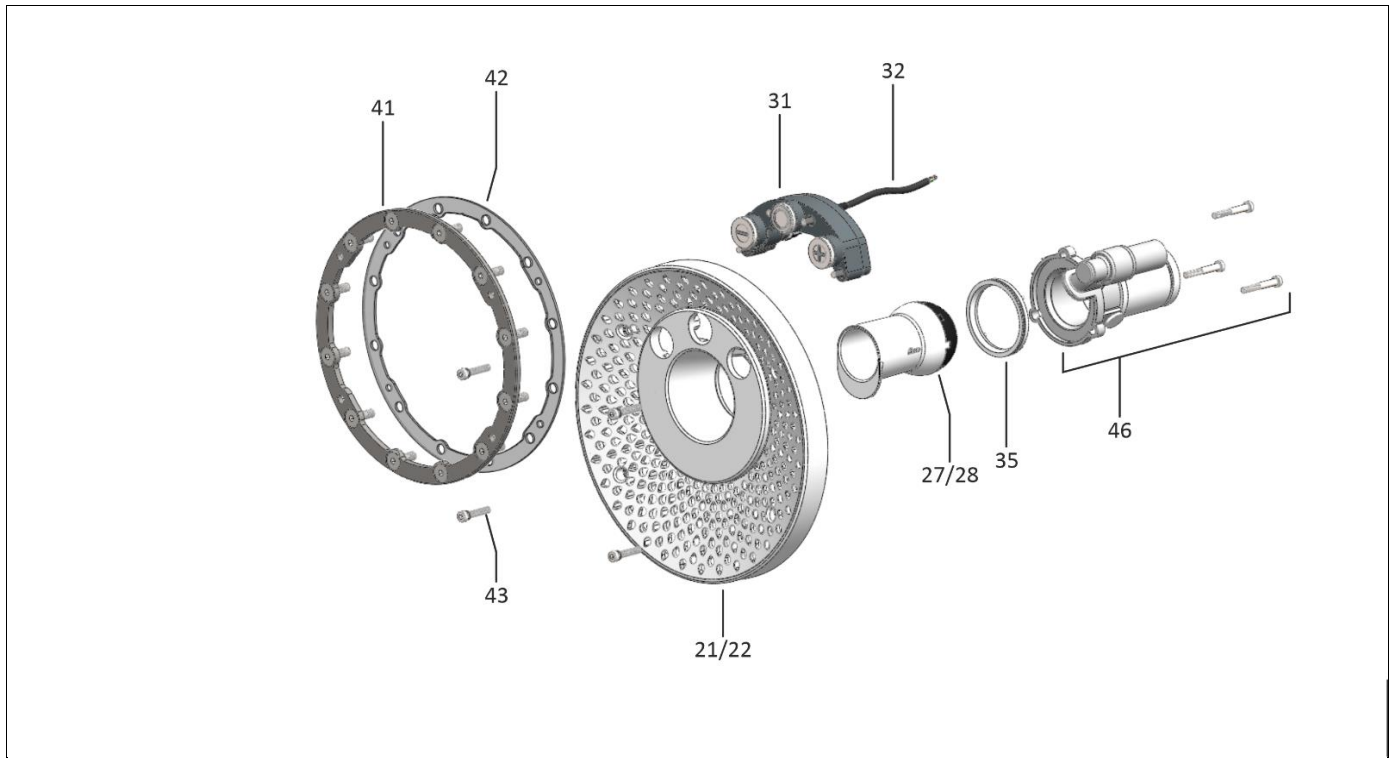

Fig. 43

11.6. Assembly kit INOX – sensor control

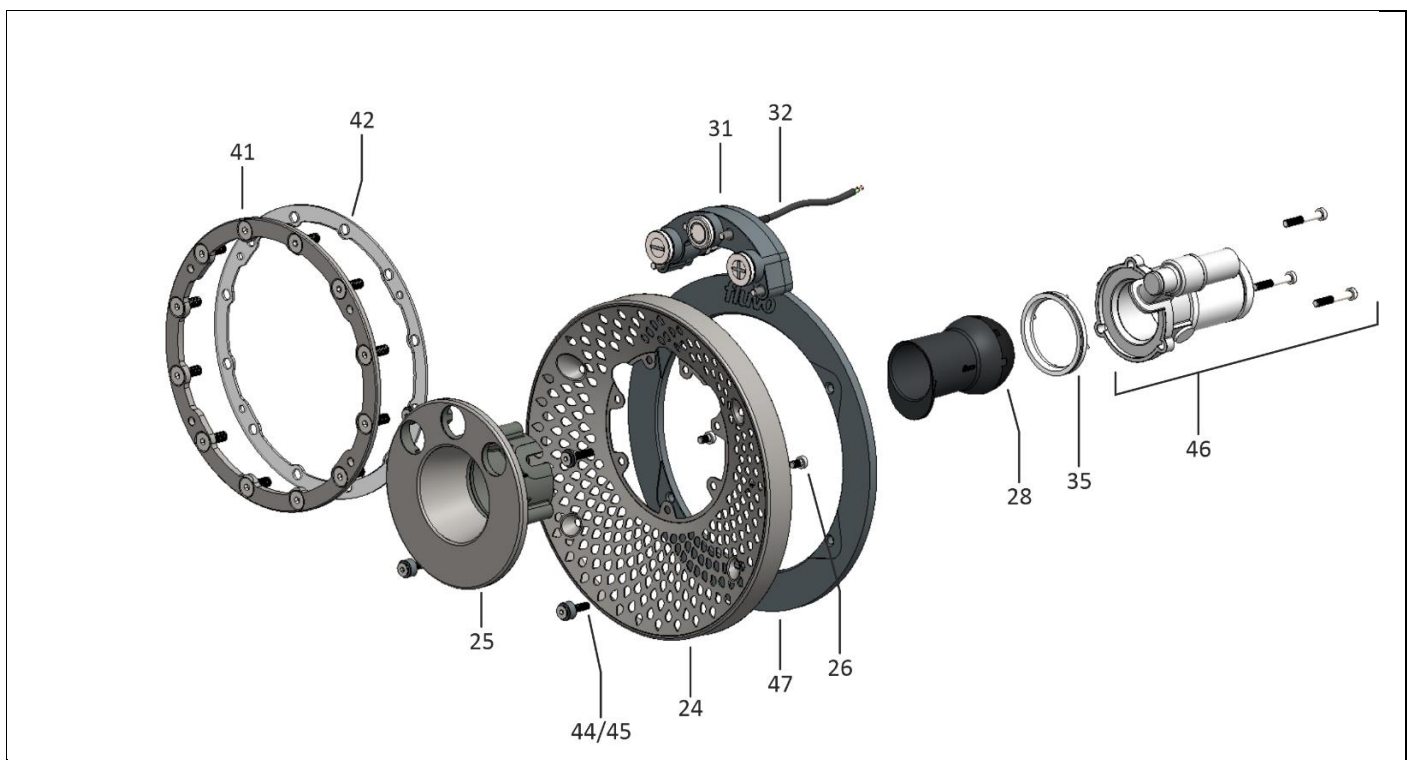

Fig. 44

schmalenberger
strömungstechnologie

Im Schelmen 9 – 11
D-72072 Tübingen / Germany



+49 (0)7071 70 08 – 0
+49 (0)7071 70 08 - 10 (Fax)
www.fluvo.de
info@schmalenberger.de

© 2021 Schmalenberger GmbH + Co. KG; All rights reserved
This document is subject to change without notice

XANAS®
27258-E