

## CG700 rondo

D

F

GB

### Operating Instructions

I

Translation of the original

E

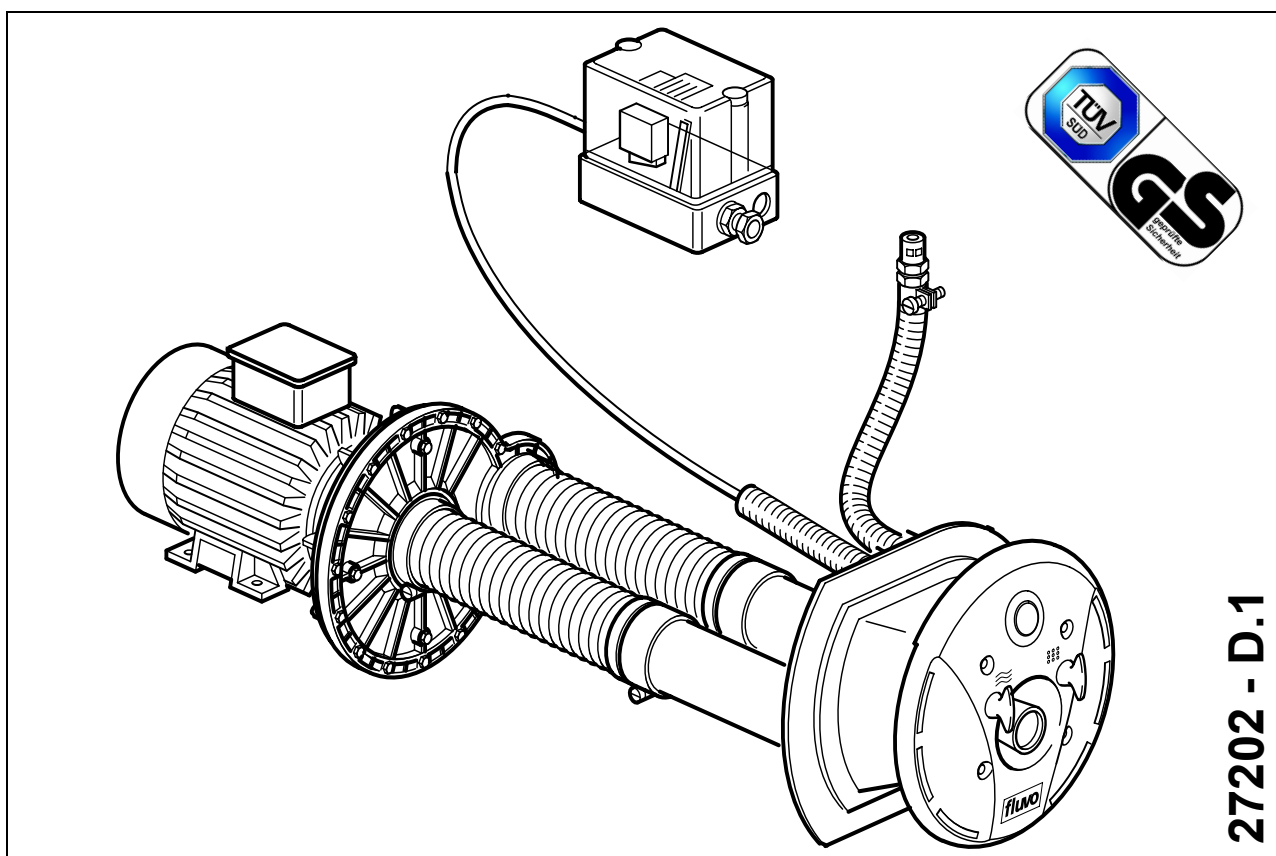

27202 - D.1



# Contents

<b>1</b>	<b>General .....</b>	<b>4</b>
1.1	Guarantee notice .....	4
1.2	General .....	4
1.3	Usage Instructions .....	4
<b>2</b>	<b>Safety Instructions .....</b>	<b>4</b>
2.1	General .....	4
2.2	Symbols .....	5
<b>3</b>	<b>Unit Description / General Technical Data .....</b>	<b>5</b>
3.1	Technical Data .....	5
3.2	Device Units .....	6
<b>4</b>	<b>Installation Site Specifications / Installation .....</b>	<b>8</b>
4.1	Base frames for the installation .....	8
4.2	Planning the pump pit .....	9
4.3	Installation preparations / Concrete pool .....	10
4.4	Installation preparations / Pre-fabricated pool .....	11
4.5	Installation preparations / Wooden-liner pool .....	11
4.6	Installation - general .....	12
4.7	Mounting the installation kit / Pre-fabricated pool .....	12
4.8	Mounting the installation kit / Wooden-liner pool .....	13
4.9	Pump Kit Installation .....	14
4.10	Connection to the pool .....	14
4.11	Connection to the pump .....	15
4.12	Installing the switchgear cabinet .....	15
4.13	Non-return air valve installation .....	16
4.14	Installation of the face plate assembly - general .....	16
<b>5</b>	<b>Electrical connections .....</b>	<b>18</b>
5.1	Electrical Connections - general .....	18
5.2	Electrical connections AC .....	19
5.3	Electrical connections three-phase current .....	20
<b>6</b>	<b>Start-up / Operating .....</b>	<b>21</b>
<b>7</b>	<b>Fault Assistance .....</b>	<b>22</b>
<b>8</b>	<b>Shutdown / Overwintering .....</b>	<b>23</b>
8.1	Empty the pool .....	23
8.2	Face plate assembly overwintering .....	23
8.3	Draining the pump .....	24
<b>9</b>	<b>Maintenance and Repair .....</b>	<b>24</b>
9.1	General .....	24
9.2	Maintenance .....	24
9.3	Repairs .....	24
<b>10</b>	<b>Spare parts .....</b>	<b>24</b>
<b>11</b>	<b>Spare parts list an drawing .....</b>	<b>25</b>
11.1	Spare parts list .....	28

## **1 General**

### **1.1 Guarantee notice**

If the instructions contained in this operator's manual are not observed then any claims under guarantee shall be void.

### **1.2 General**

All parts coming into contact with media are designed for water quality to **DIN 19643**.

The counter-current swimming unit (counter-current unit) is of state-of-the-art technology. It has been manufactured with great care and is subject to constant quality checks. It has been approved by the German Technical Inspectorate (TÜV) and awarded the TÜV-GS (safety standard) mark.

The operator's manual contains important instructions on how to use the counter-current unit safely, properly and economically. The instructions must be strictly adhered to in order to avoid danger and to ensure that the counter-current unit has a long useful life.

This manual does not take into account local regulations, the observance of which is the responsibility of the operator – also on behalf of installation personnel that may be involved.

The performance label specifies the machine series, the frame size, the most important operating data and the serial number. Please be sure to quote it in case you require more information and also when placing subsequent orders or ordering spare parts.

### **1.3 Usage Instructions**

The counter-current unit was designed for use in private swimming pools. Consequently it must not be installed in public swimming pools. Neither the entire unit nor parts thereof must be used in other systems. You are expressly directed to use it only in accordance with these instructions.

The counter-current unit must not be operated beyond the parameters stated in the technical data (3.1) . In case of doubt, please contact your customer service or the manufacturer.

## **2 Safety Instructions**

### **2.1 General**

- Make sure that the relevant safety regulations and laws are observed in the operating company and / or country where the counter-current systems are to be used.
- Use the counter-current system only if it is in perfect technical condition, in accordance with the regulations, observing safety requirements and danger conditions and strictly adhering to all the instructions in the operator's manual!
- Promptly remedy any faults that could influence safety.
- The details on the type plate must correspond to the electrical supply being connected to.
- Prior to carrying out repairs to the counter-current system it must be isolated from the electrical supply and protected from unintentional switching on.
- Regardless of what nature they may be, repairs must only be carried out by qualified persons and the counter-current system must be emptied first.

- The operator must ensure that
  - the operator's manual is always available for users to read,
  - instructions in the operator's manual are being observed,
  - the counter-current system is immediately stopped if abnormal electrical voltages, temperatures, noises, vibrations, leakages or other faults should arise.



For more details of safety instructions please see the operator's manual WK (27220).

## 2.2 Symbols

In these operating instructions the following symbols are used to draw your special attention to dangers:



### **Warning! Risk of injury! / Warning! Risk of damage!**

This symbol warns you of dangers through mechanical effects and also warns of handling that could damage the product.



### **Warning! Mortal danger!**

This sign warns you of the danger from electric shocks.

Notices attached directly to the counter-current system, e.g. the arrow indicating the direction of rotation, must always be observed and maintained in a clearly legible condition.

## 3 Unit Description / General Technical Data

- The *fluvo* counter-current system CG700 rondo complies with VDE (Association of German Engineers) regulations.
- The electric motor and the water conducting plastic pump are electrically separated.
- The electric motor complies with protection class IP 55.
- The entire counter-current system complies with protection class I.

The counter-current system is delivered as 3 assemblies:

1. Pump kit
2. Assembly kit
3. Installation kit

### 3.1 Technical Data

System type:	CG700 1.5	CG700 1.5 WS*	CG700 1.9	CG700 1.9 WS*	CG700 3.0
Capacity	1.5 kW	1.5 kW	1.9 kW	1.9 kW	3 kW
Voltage [V]	400 V Y / 230 V Δ	230 V ~	400 V Y / 230 V Δ	230 V ~	400 V Y / 230 V Δ
Frequency	50 Hz	50 Hz	50 Hz	50 Hz	50 Hz
Current	2,86 A	9.5 A	3.6 A	11.5 A	5,75 A
Speed	2840 rpm	2790 rpm	2850 rpm	2820 rpm	2810 rpm
Delivery capacity	42 m³/h	42 m³/h	48 m³/h	48 m³/h	60 m³/h
Delivery pressure	1.2 bar	1.2 bar	1.4 bar	1.4 bar	1.9 bar
Max. speed 2 m from the nozzle	1.15 m/sec.	1.15 m/sec.	1.3 m/sec.	1.3 m/sec.	1.6 m/sec.
Max. water temperature	50 °C	50 °C	50 °C	50 °C	50 °C
Expected sound pressure level	65 + 2 dB (A)	65 + 2 dB (A)	67 + 2 dB (A)	67 + 2 dB (A)	70 + 2 dB (A)
Weight	26 kg	26 kg	27 kg	27 kg	39 kg

\*WS = AC = Alternating current

### 3.2 Device Units

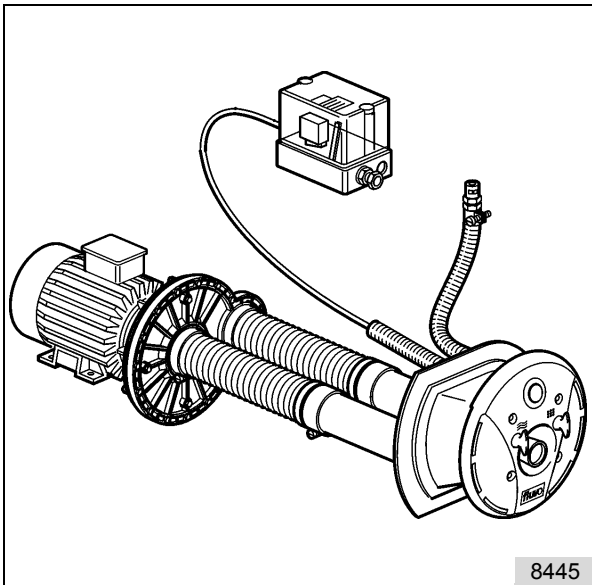

fig. 1

#### Overview of the Counter-current unit

The counter-current unit consists of:

1. Pump kit
2. Assembly kit (face plate assembly)
3. Installation kit

The installation kit is always different depending on the pool type.

There are 4 kinds of pool:

- Concrete-tile pool
- Concrete-liner pool
- Pre-fabricated pool (steel, plastic or similar)
- Wooden-liner pool

\* The item numbers correspond to the numbers in the parts list.

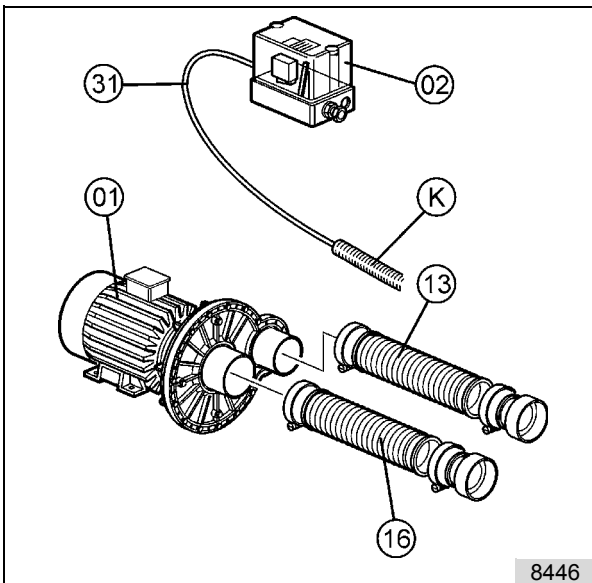

fig. 2

#### I - Pump kit

The pump kit consists of:

- |                          |          |
|--------------------------|----------|
| 1. Pump assembly         | Item 01* |
| 2. Suction hose          | Item 16  |
| 3. Pressure hose         | Item 13  |
| 4. Switching tube ø 4 mm | Item 31  |
| 5. Switchgear cabinet    | Item 02  |
| 6. Protective hose       | Item K   |

\*The pump kit is always identical no matter what sort of pool it is intended for.

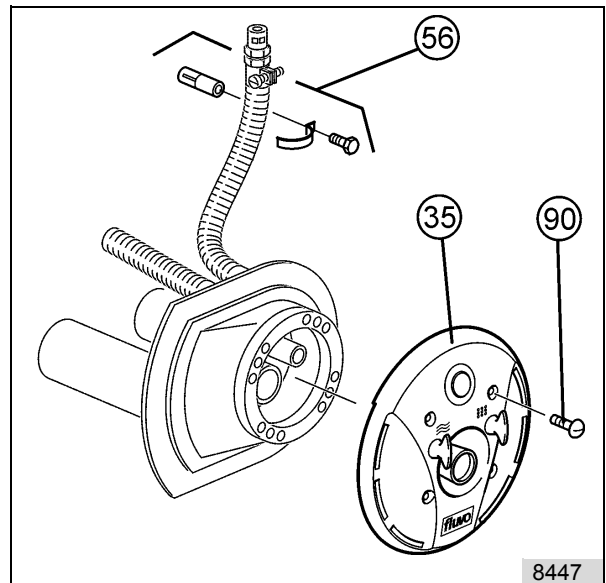

fig. 3

#### II - Assembly kit

The assembly kit includes:

- |                            |         |
|----------------------------|---------|
| 1. Face plate assembly     | Item 35 |
| 2. Mounting screws         | Item 90 |
| 3. Air line fixing bracket | Item 56 |

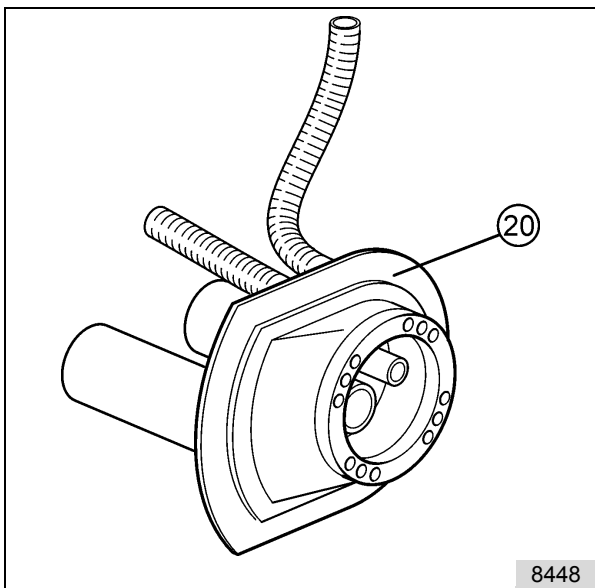

fig. 4

### III - Installation kit for concrete-tile pools

The installation kit consists of:

- |            |         |
|------------|---------|
| 1. Housing | Item 20 |
|------------|---------|

**Note:** The housing is concreted into the concrete wall of the pool. Details of this can be found in section 4 of this manual.

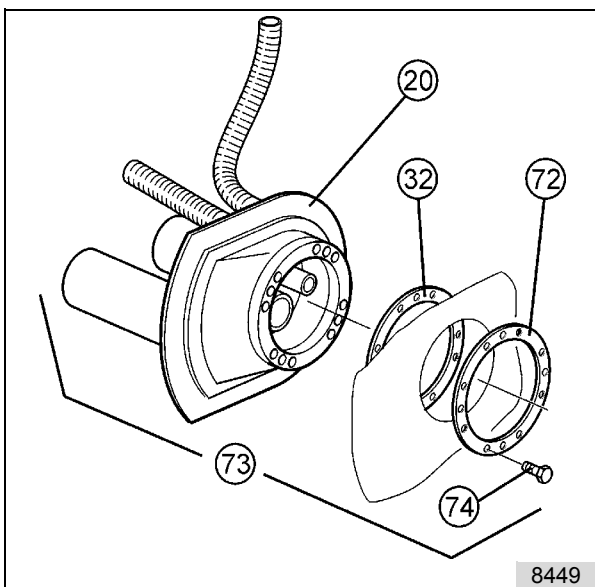

fig. 5

### III - Installation kit for concrete-tile pools

The installation kit + assembly components (Item 73) consists of:

- |                     |         |
|---------------------|---------|
| 1. Installation kit | Item 20 |
|---------------------|---------|

**Note:** The housing is concreted into the concrete wall of the pool. Details of this can be found in section 4 of this manual.

- |                    |         |
|--------------------|---------|
| 2. Clamp ring      | Item 72 |
| 3. Clamp gasket    | Item 32 |
| 4. Mounting screws | Item 74 |

**Note:** Parts 2 to 4 are delivered with the face plate assembly.

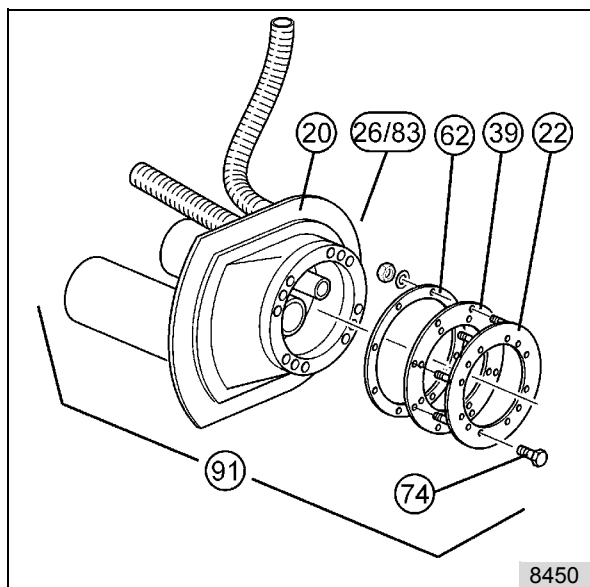

fig. 6

### III - Installation kit for pre-fabricated pools

The installation kit (Item 91) consists of:

- |                     |             |
|---------------------|-------------|
| 1. Housing          | Item 20     |
| 2. Clamp ring       | Item 22     |
| 3. Clamp gasket     | Item 39     |
| 4. Hold-ring        | Item 62     |
| 5. Mounting screws  | Item 74     |
| 6. Nuts and washers | Items 26+83 |

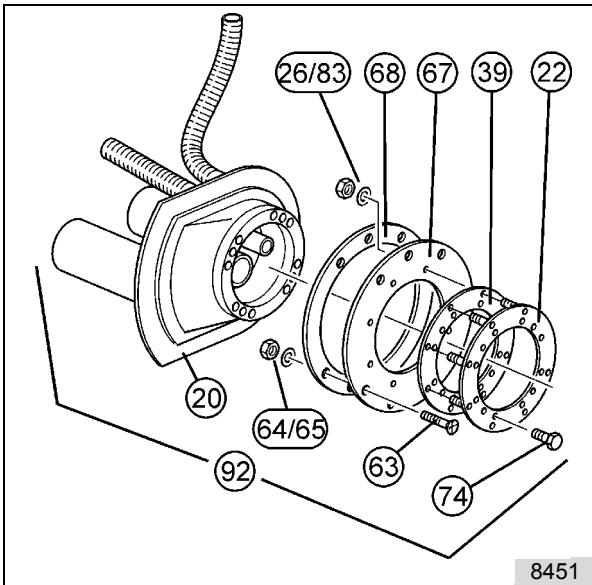

fig. 7

### III - Installation kit for wooden-liner pool

The installation kit (Item 92) consists of:

- |                     |                     |
|---------------------|---------------------|
| 1. Housing          | Item 20             |
| 2. Clamp ring       | Item 22             |
| 3. Clamp gasket     | Item 39             |
| 4. Hold-ring        | Item 68             |
| 5. Hold-ring        | Item 67             |
| 6. Mounting screws  | Items 63+74         |
| 7. Nuts and washers | Items 64/65 + 26/83 |

## 4 Installation Site Specifications / Installation



### Warning! Risk of damage!

As the pumps are not self-priming, the installation must be under water level. Make sure you take this into account during the installation planning phase.

### 4.1 Base frames for the installation

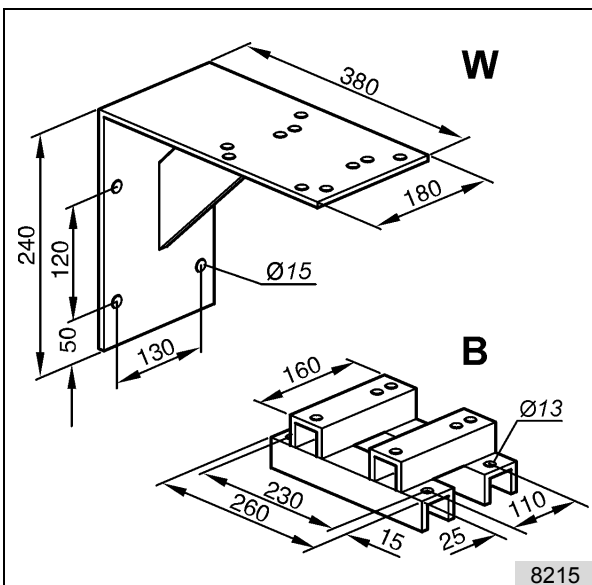

fig. 8:

There are two base frames available that must be ordered separately to suit local circumstances.

1. **W** = for wall mounting
2. **B** = for floor mounting

## 4.2 Planning the pump pit

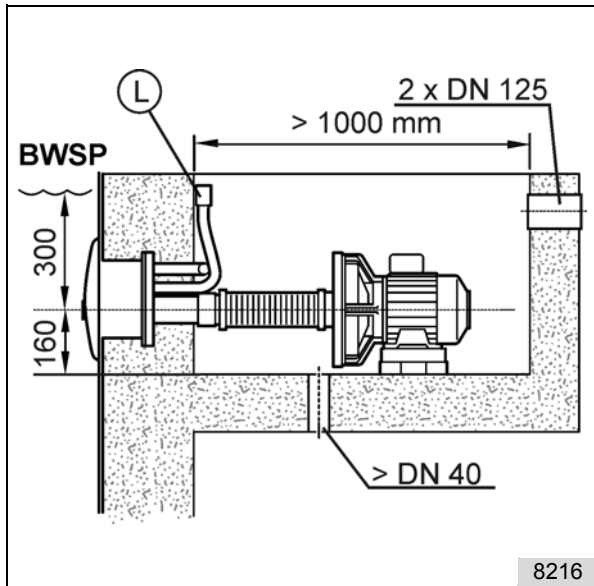

fig. 9: Cross-sectional view of the pump pit

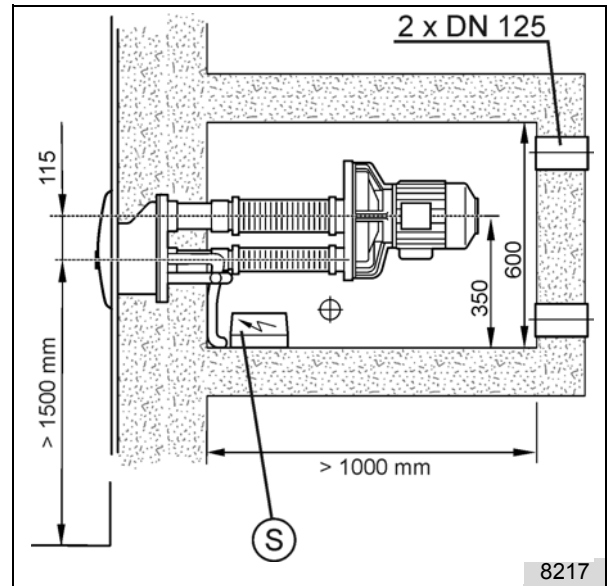

fig. 10: Top view of the pump pit

*BWSP* Pool water level  
*L* Air valve

*S* Switchgear cabinet

### When planning a pump duct take into account:

1. Clear dimensions min. 1000 x 600 x 600
2. Return connection min. 300 mm under the pool water level
3. Leakage water discharge pipe-end min. DN 40
4. Cooling air supply for the motor min. 2x DN 125. Minimum clearance of the motor cooling air inlet to the wall = 200 mm.
5. Be sure to cover the pump pit if it is installed in the open air.



### Warning! Mortal danger!

The mains power supply cable must be equipped with an all-pole separator with a contact opening of 3 mm.

6. The position of the non-return air valve (L) must always be over the pool water level (BWSP).
7. The position of the switchgear cabinet (S) must always be over the pool water level (BWSP).
8. In case of leakage from the pump, a suitable water drainage must be provided!

### 4.3 Installation preparations / Concrete pool

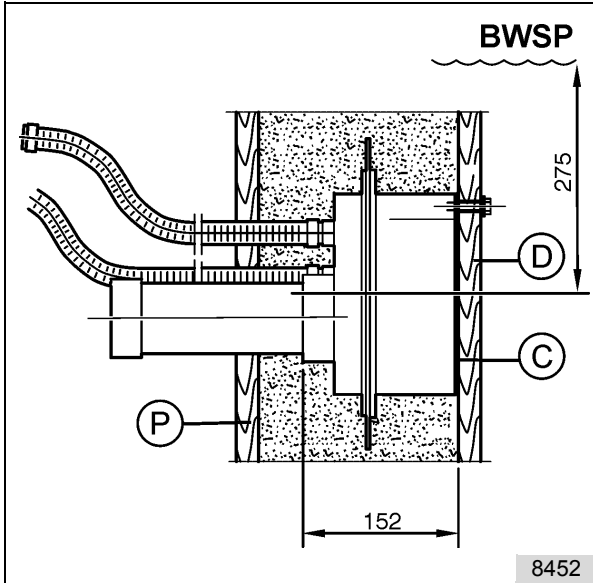

fig. 11

- BWSP* Pool water level  
*C* Mounting protection film  
*D* Pool-side formwork board  
*P* Outer formwork board

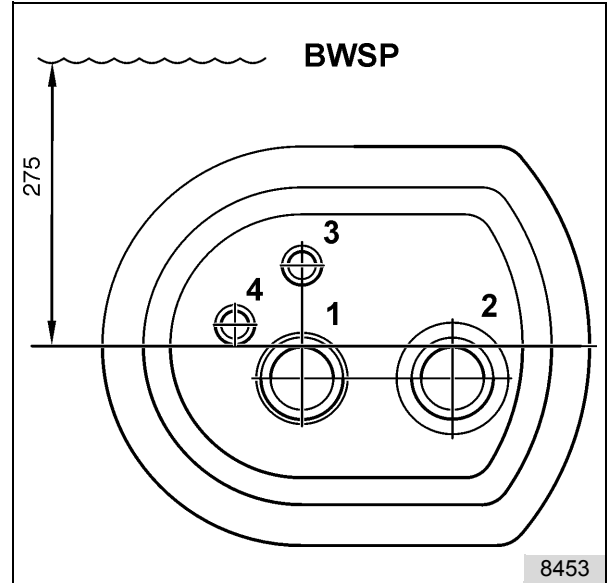

fig. 12: Rear view of the installation kit

- 1 Pressure pipe DN 50  
 2 Suction pipe DN 65  
 3 Switching tube  
 4 Air supply to the non-return air valve

#### Tailor the installation kit:

Place the installation kit on the formwork board and transfer the bore holes. Bore the holes into the pool-side formwork board (D). Mark out and cut holes into the outer formwork board (P) for the suction and pressure supplies and the two hoses.

Screw the installation kit complete with the mounting protection film (C) tightly to the pool-side formwork board.



#### Warning! Risk of damage!

- The installation kit must be horizontal.
- The distance between the centre of the installation kit and the water level (**BWSP**) must be 275 mm.

#### 4.4 Installation preparations / Pre-fabricated pool

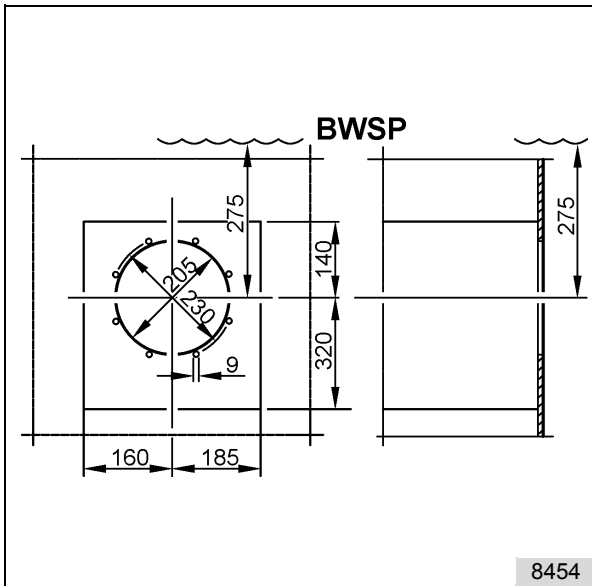

fig. 13: Boring diagram

##### Tailor the installation kit:

Cut the cavity  $\varnothing$  205 and the mounting holes  $\varnothing$  9 into the pool wall.



##### Warning! Risk of damage!

The hold-ring (62) must be used as a template.

For rear filling the pool ensure that there is a cavity at least the size of the dotted lines.

#### 4.5 Installation preparations / Wooden-liner pool

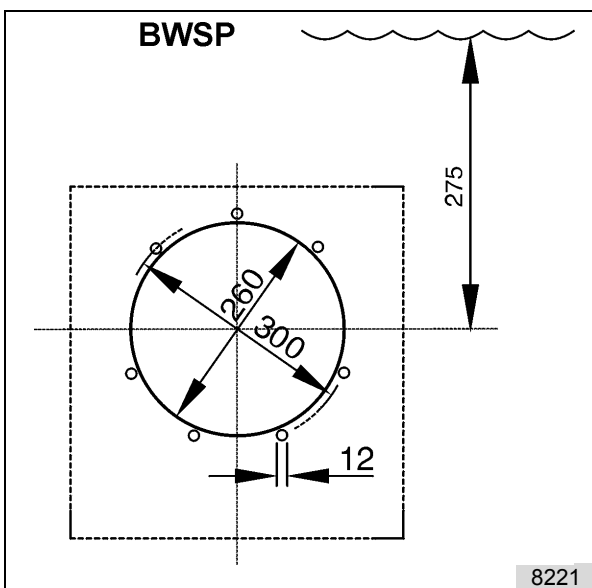

fig. 14: Boring diagram

##### Tailor the installation kit:

Cut the cavity  $\varnothing$  260 and the mounting holes  $\varnothing$  12 into the pool wall.



##### Warning! Risk of damage!

The hold-ring (68) must be used as a template.

Take note of the asymmetrical position of the holes!

#### 4.6 Installation - general

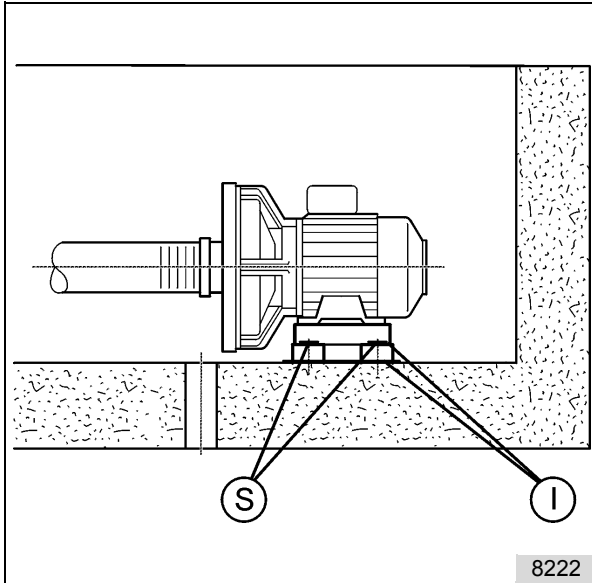

fig. 15

Place the base frame in the desired position. Fasten the base frame with 4 screws (S).



#### Warning!

The base frame should be installed in such a way that it is insulated from the floor and the wall (I) to avoid the possibility of external voltage transmissions.

I      *Insulation*  
S      *Screw*

#### 4.7 Mounting the installation kit / Pre-fabricated pool

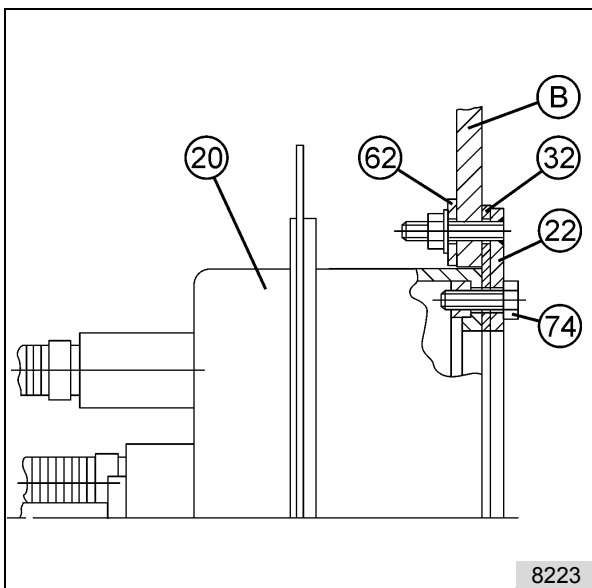

fig. 16

B      *Pool wall*  
20      *Housing*  
22      *Clamp ring*  
32      *Clamp gasket*  
62      *Hold-ring*  
74      *Hexagon screw*

Mount the clamp ring (22) with the clamp gasket (32) and the hold-ring (62) to the pool wall. The sealing contact faces must be clean and smooth.

Then mount the housing (20) on the clamp ring (22) with the screws (74).



#### Warning!

The housing (20) must be mounted so that the connection for the membrane switch (MS) is at the top.

### 4.8 Mounting the installation kit / Wooden-liner pool

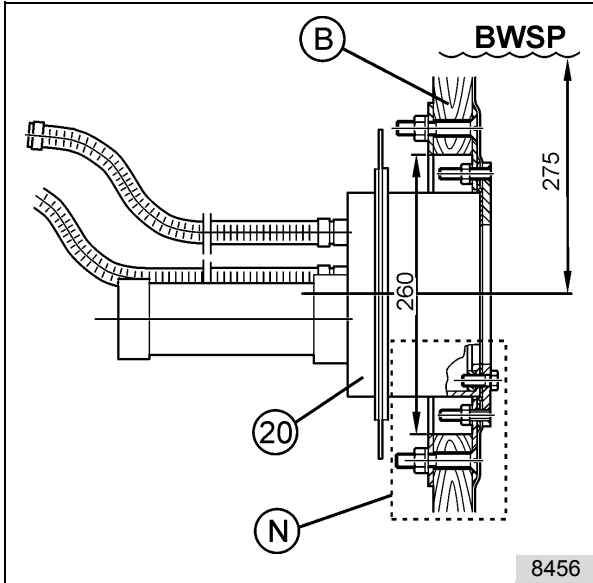

fig. 17

- B Pool wall
- N For details see fig. 18
- BWSP Pool water level
- 20 Housing
- 22 Clamp ring

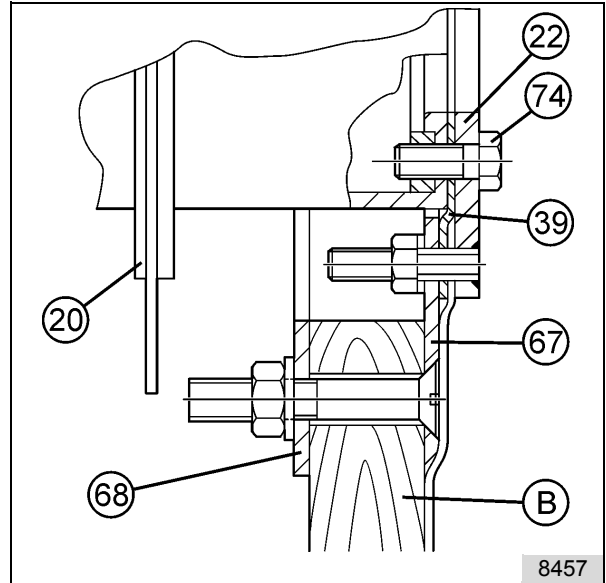

fig. 18: Detail from fig. 17

- 39 Clamp gasket
- 67 Hold-ring
- 68 Hold-ring
- 74 Screw

Mount the hold-ring (67) with the hold-ring (68) to the pool wall.

Hang in the liner. Fasten the liner and the clamp gasket (39) together with the clamp ring (22) and cut out the liner.

Then mount the housing (20) on the clamp ring (22) with the screws (74).



**Warning!**

The housing (20) must be mounted so that the connection for the membrane switch (MS) is at the top.

#### 4.9 Pump Kit Installation

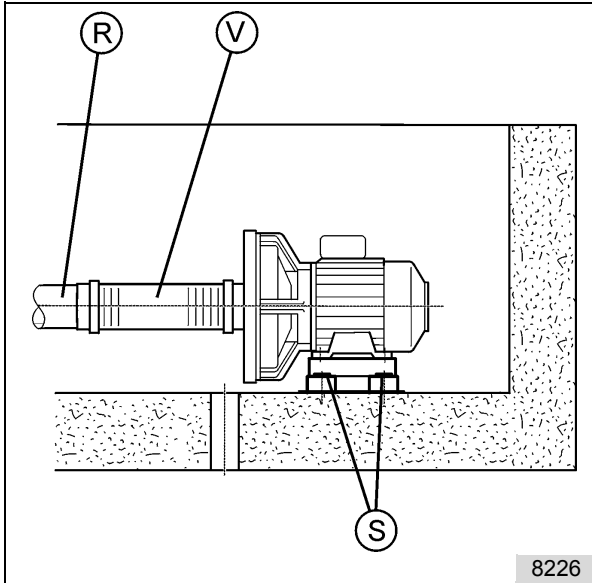

fig. 19

- R* Pipework  
*S* Hexagon screws  
*V* Adaptor

Mount the pump free of all tension with the hexagon screws M8 (S) on the base frame.

#### Warning!



1. Do not use any vibration dampers between the pump and the base frame.
2. If the pipework (R) to the pump is longer than 6 m then the nominal width must be increased.
  - Suction side from DN 65 to a min. of DN 80
  - Pressure side from DN 50 to a min. of DN 65.
3. Then always mount the adaptors (V) on the pump body.

#### 4.10 Connection to the pool

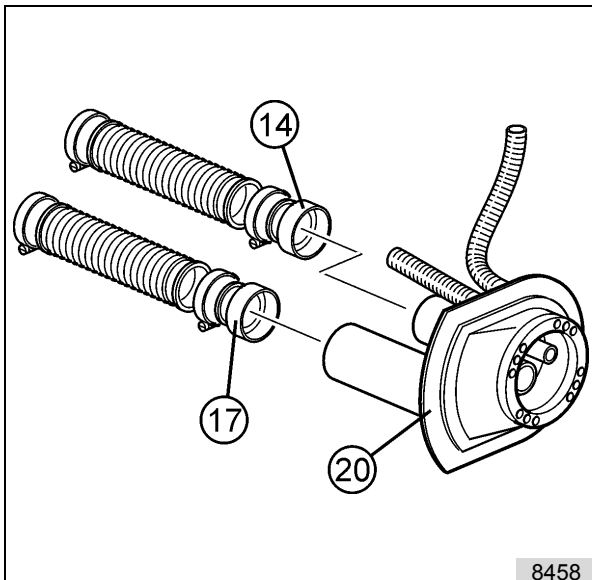

fig. 20

- 14* Return connection DN 50  
*17* Suction connection DN 65  
*20* Housing

Stick the adaptors (14+17) onto the pipe connections on the housing (20). Alternatively, by using pipework, stick to the pump-side end of the pipework.

#### Warning!



Always be sure to lay the pipework using bends and not angles to keep the pipe resistance to a minimum.

#### 4.11 Connection to the pump

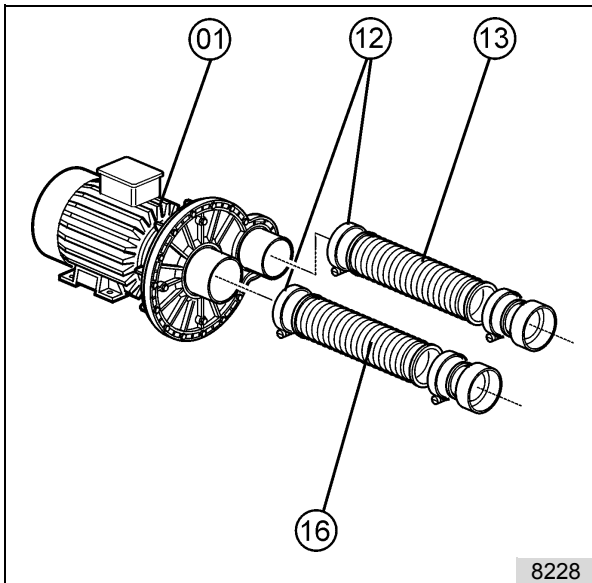

fig. 21

- 01 Motor
- 12 Air pipe clamp
- 13 Hose line pressure side
- 16 Hose line suction side

Connect the hose lines (13 pressure side + 16 suction side) to the pump body. Use the corresponding air pipe clamps (12) on both sides for this.



#### Warning!

Make sure that the connections from the body of the pump to the installation kit / pipework are as nearly aligned as is possible.

The hose lines must always be attached to the pump on the one side (compensator function), see diagram.

#### 4.12 Installing the switchgear cabinet

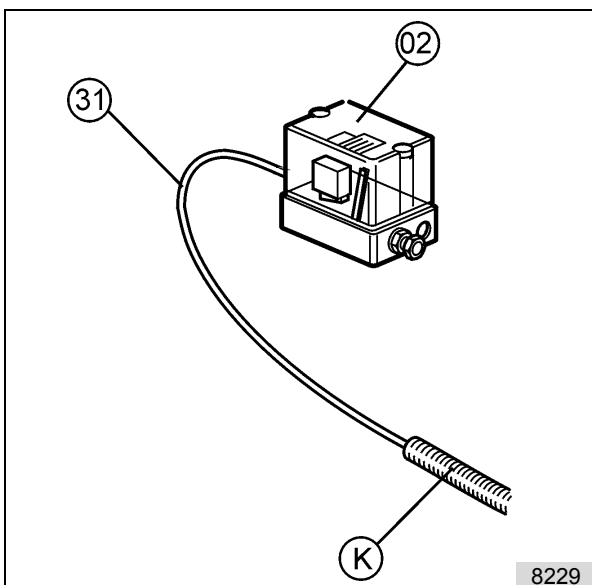

fig. 22

- K Protective hose
- 02 Switchgear cabinet
- 31 Switching tube

Mount the switchgear cabinet (02) as close as possible to the installation kit. Also please observe the instructions in chapter 4.2.

Fix the switching tube (31) onto the nipple in the protective hose (K).



#### Warning!

Be careful not to put a kink in the switching tube and keep it as short as possible, maximum length 8 m.

#### 4.13 Non-return air valve installation

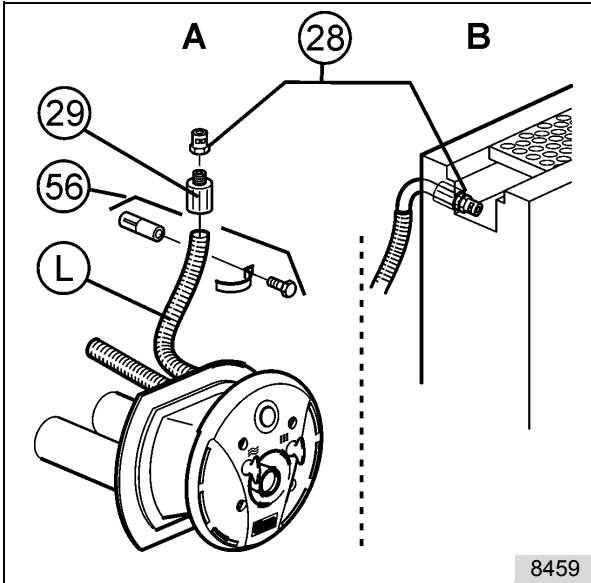

fig. 23

- 28 Non-return air valve
- 29 Air line hose tail
- 56 Fixing bracket

Stick the air line hose tail (29) to the air hose (L). Screw the non-return air valve (28) onto the air line hose tail (29). Fasten the non-return air valve with the fixing bracket (56) to the pool wall or similar. In the case of a ground level overflow, place the non-return air valve in the duct, see detail "B".



#### Warning!

To position the non-return air valve also please observe the information under chapter 4.2.

#### 4.14 Installation of the face plate assembly - general

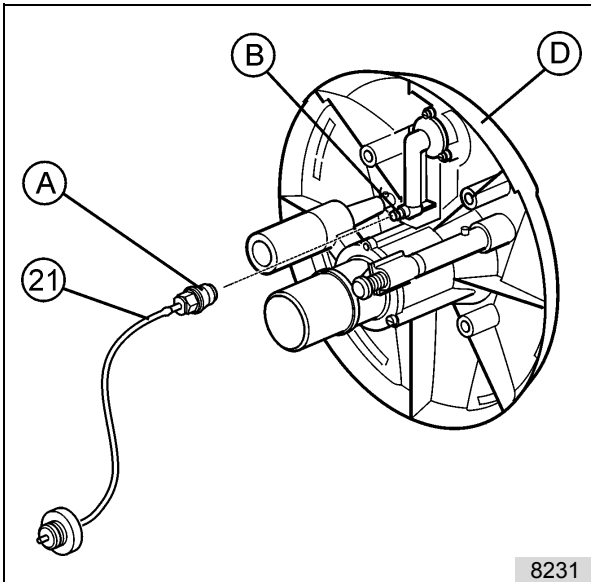

fig. 24

- A Hose coupling
- B Plug sleeve
- D Face plate assembly
- 21 Hose

Drain the pool water, if already filled, to below the installation kit. Firmly place the hose (21) with the hose coupling (A) onto the plug sleeve (B) on the face plate assembly (D). With that the air button is connected to the switchgear cabinet.

#### 4.14.1 Face plate assembly installation / Concrete-tile pool

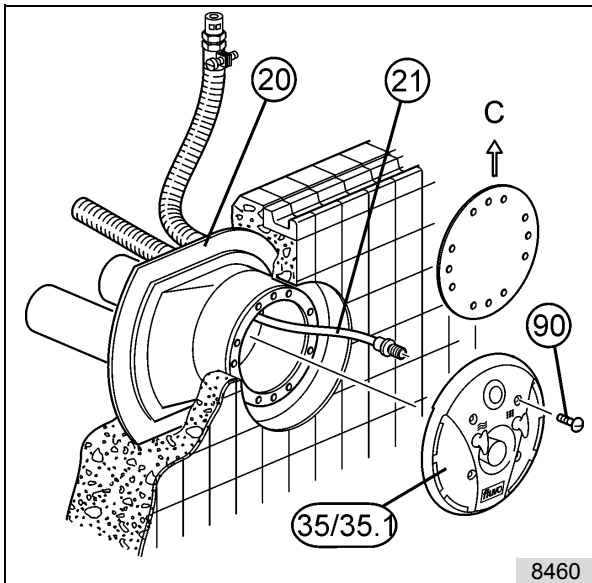

fig. 25

C	Mounting protection film
20	Housing
21	Switching tube
35/35.1	Face plate assembly
90	Screw

Remove the mounting protection film (C). After connecting the air button, put on the face plate assembly (35/35.1), this allows the pressure connection and air connection to slide into one another. Fasten to the housing (20) with the screws (90.1).



#### Warning!

Make sure that there is not a kink in the switching tube (21), do not lay it in a loop and do not shorten it!

#### 4.14.2 Face plate assembly installation / Concrete-liner pool

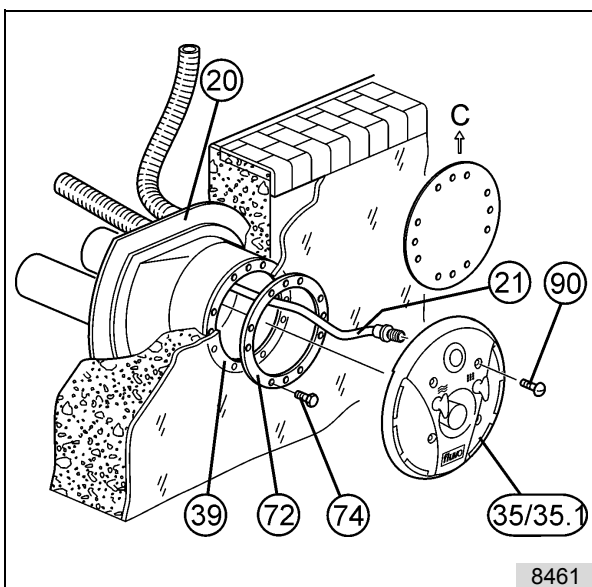

fig. 26

C	Mounting protection film
20	Housing
21	Switching tube
35/35.1	Face plate assembly
39	Clamp gasket
72	Clamp ring
74	Screw
90	Screw

Remove the mounting protection film (C). Place the clamp gasket (39) between the installation housing (20) and the liner and screw the clamp ring (72) to the installation housing using the screws (74). The sealing contact faces must be clean and smooth. Now cut out the pool liner.

After connecting the air button, put on the face plate assembly (35/35.1), this allows the pressure connection and air connection to slide into one another (refer to fig. 24). Fasten to the clamp ring (72) with the screws (90).



#### Warning!

Make sure that there is not a kink in the switching tube (21), do not lay it in a loop and do not shorten it!

### 4.14.3 Face plate assembly installation / Pre-fabricated pool and Wooden-liner pool

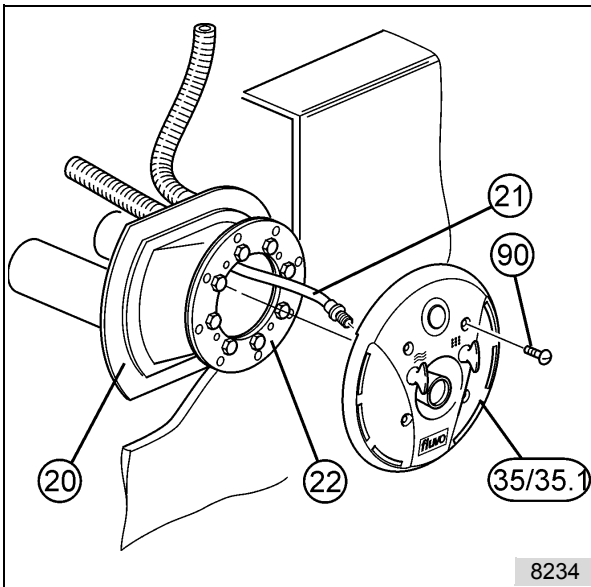

fig. 27: Pre-fabricated pool

- 20 Housing
- 21 Switching tube
- 22 Clamp ring

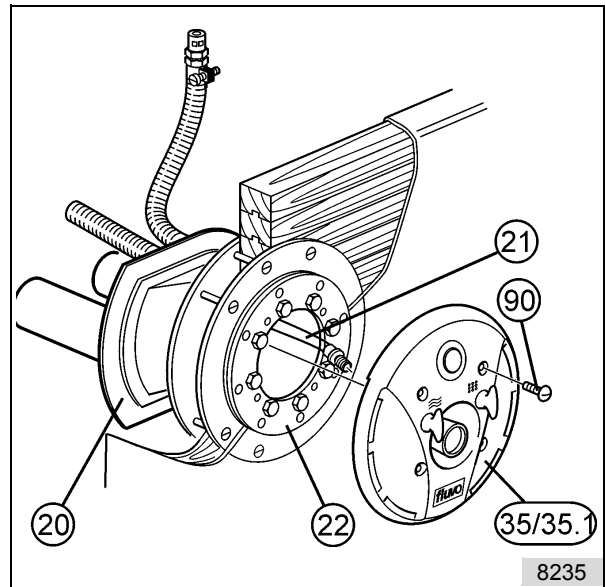

fig. 28: Wooden-liner pool

- 35/35.1 Face plate assembly
- 90 Screw

After connecting the air button, put on the face plate assembly (35/35.1), this allows the pressure connection and air connection to slide into one another. Fasten to the clamp ring (22) with the screws (90).



**Warning!**

Make sure that there is not a kink in the switching tube (21), do not lay it in a loop and do not shorten it!

## 5 Electrical connections

### 5.1 Electrical Connections - general

The electrical connections to the counter-current swimming system must be carried out by a specialised company in the electrical engineering branch approved by the local energy provider, taking into account the technical connection requirements.



**Warning! Mortal danger!**

The connections must be carried out by a qualified electrician. For this see for example the **Technical Connection Conditions for heavy current from the local power supply company**, the **Regulations of the Electrical Trade VBG (§3)** and **DIN VDE 1000-10 / 1995-5**. The relevant **DIN VDE directives 0100** and where there is a risk of explosion **0165** must also be observed. If the installation is not carried out properly, there is a risk of getting electric shocks!



**Warning!**

Compare the available power supply voltage with the details on the motor's factory plate and select the appropriate switching. We recommend the use of a motor protection facility. Connect the motor in accordance with the circuit diagrams in the following chapters.

**Please observe:**

- The mains power connection must be a fixed connection.
- Under no circumstances must there be any conducting connection between the metal parts of the motor and the water.
- The mains power supply cable must be equipped with an all-pole separator with a contact opening of 3 mm.
- At the marked connection terminal (at the foot of the motor or next to the terminal box) an equalising potential with a cross-section of 10 mm<sup>2</sup> must be fitted.

**5.2 Electrical connections AC**

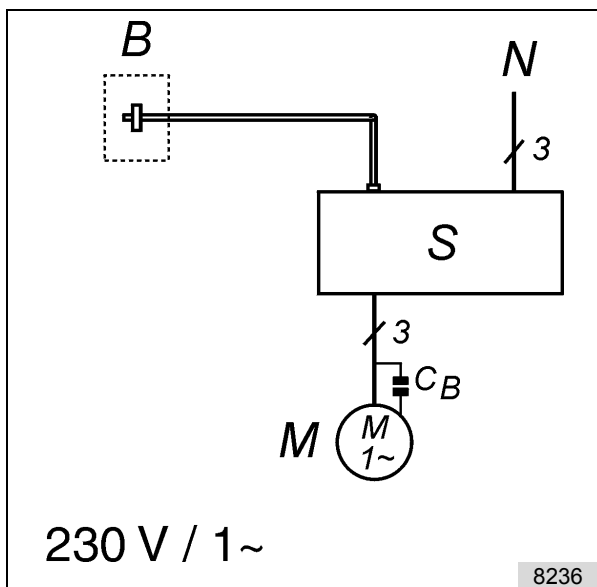

fig. 29

Mains voltage: 230 V for 1 ~ AC  
 Mains power supply cable: 3 x 2.5 mm<sup>2</sup>  
 Pump connection cable: 3 x 2.5 mm<sup>2</sup>  
 Fuse: 16 A passive

**B** = Control unit in the pool  
**M** = Motor of the circulation pump  
**N** = Mains power supply (230 V for 1~)  
**S** = Switchgear cabinet  
**C<sub>B</sub>** = Capacitor

Connection cable, for example, HO7RNF, all further details required for making connections can be found in chapter 3.1.

**Protective measures:**

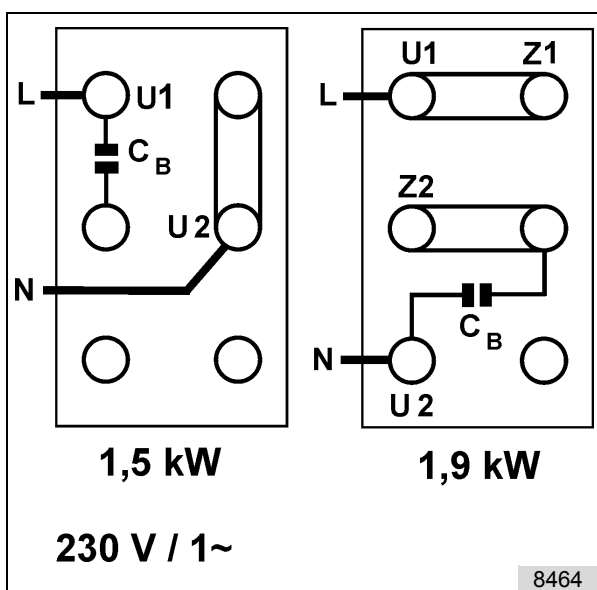

fig. 30: Basic circuit diagram for 230 V for 1 ~ AC



An earth leakage circuit breaker (nominal fault current ≤30 mA) must be fitted to the mains power supply!



**Important! Watch the order of the terminal bridges!**

See the inside of the terminal box lid or enclosed circuit diagram. Please be sure to observe instructions from the motor manufacturer!

**L** External conductor  
**N** Neutral conductor

### 5.3 Electrical connections three-phase current

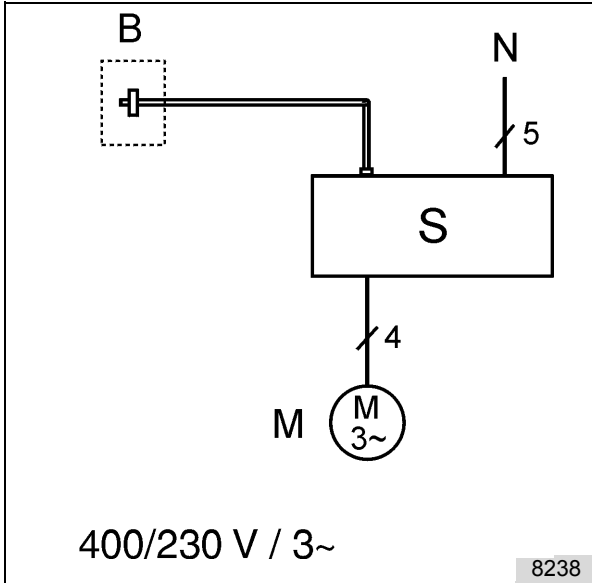

fig. 31: Basic circuit diagram for 400/230 V three-phase current

Mains voltage: 400/230 V  
for 3~ AC

Mains power supply connection cable: 5 x 2.5 mm<sup>2</sup>

Pump connection cable: 4 x 2.5 mm<sup>2</sup>

Fuse: 16 A passive

*B = Control unit in the pool*  
*M = Motor of the circulation pump*  
*N = Mains power supply (400/230 V 3 ~)*  
*S = Switchgear cabinet*

Connection cable, for example, HO7RNF, all further details required for making connections can be found in chapter 3.1.

#### Protective measures:

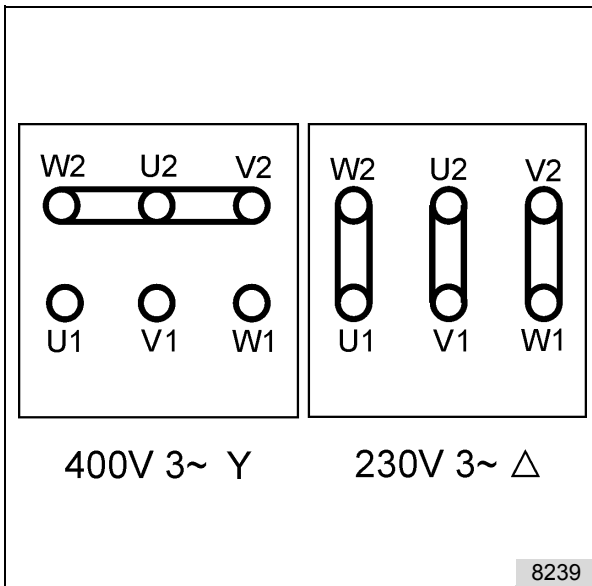

fig. 32: Basic circuit diagram for 400/230 V three-phase current



An earth leakage circuit breaker (nominal fault current  $\leq 30$  mA) must be fitted to the mains power supply!



**Important! Watch the order of the terminal bridges!**

See the inside of the terminal box lid or enclosed circuit diagram. Please be sure to observe instructions from the motor manufacturer!

*L External conductor*  
*N Neutral conductor*

## 6 Start-up / Operating

Never carry out a trial run with the motor as long as there is no water in the pump. A dry run will destroy the mechanical seal in the pump!

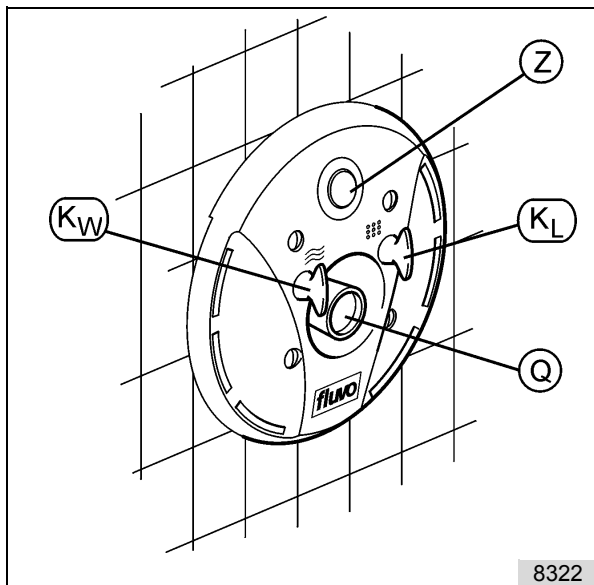

fig. 33

$K_L$	Air supply regulator knob
$K_W$	Water supply regulator knob
Q	Nozzle
Z	Switching button

- **Switching the pump on and off**

The pump is switched on by pressing the switching button (Z). After 2 seconds the pump can be switched off by pressing the button again or a signal can be sent to the pump (on-off function).

- **Water supply control**

By turning the knob ( $K_W$ ) clockwise the water supply decreases, anti-clockwise it increases.

- **Air supply control / Air bubble bath**

By turning the knob ( $K_L$ ) clockwise the air supply decreases, anti-clockwise it increases. The air supply to the water causes the water jet to become softer (air bubble bath).

- **Direction of jet**

The nozzle can be turned in any direction.

- **Counter-current swimming**

Set the maximum jet speed. Swing the nozzle (Q) so that the water layer just under the surface of the water begins to flow quickly.

- **Attaching the massage set**

Switch off the counter-current swimming system prior to attaching the impulse-massage nozzle.

Pull back the sliding sleeve (V), push the hose coupling (F) into the nozzle (D), press the sliding sleeve (V) against the nozzle (D) and pull back on the hose coupling (F). That causes the hose coupling to be locked in place.

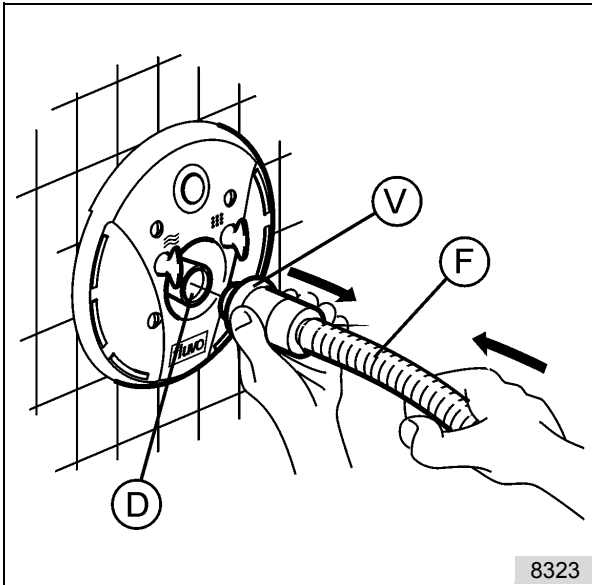

fig. 34: Attaching the massage set

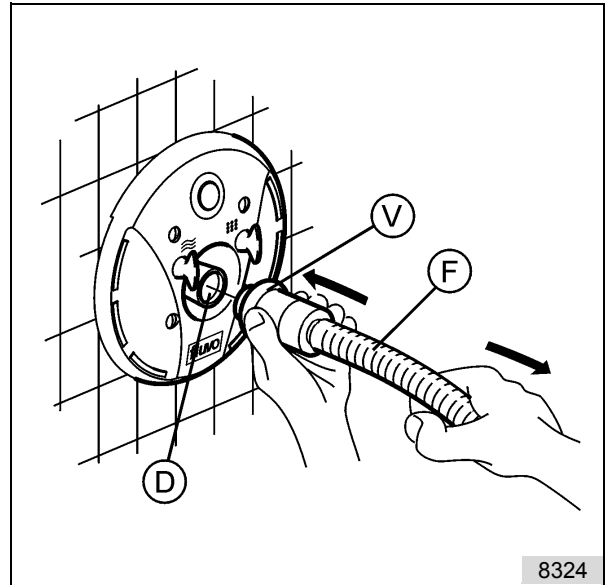

fig. 35: Detaching the massage set

*D* Nozzle  
*F* Hose coupling

*V* Sliding sleeve

• **Detaching the massage set**

Switch off the counter-current swimming system prior to detaching the impulse-massage nozzle.

Press the hose coupling (F) against the sliding sleeve (V), take a hold of it and pull it back, pull out the hose coupling.

**7 Fault Assistance**



**Warning!**

In accordance with UVV (Accident Prevention Regulations) all repairs and intervention to the unit must be carried out exclusively by qualified persons otherwise damage (accidents) could result to the user / operator.

The functional faults listed in the table are the most frequent causes of defects. If the corrective measures described are not successful, then the specialist that is called in individual cases will have to investigate the cause of the fault.

Functional fault	Possible cause	Remedy
1. Pump runs very loudly and lacks performance	Motor rotating in the wrong direction	Re-pole the motor in the terminal box and reverse the direction
	Motor blower brushes against the blower cover	Fasten the blower cover properly
2. Pump starts up heavily and slowly	A current phase is missing	Check supplies and fuses

Functional fault	Possible cause	Remedy
3. The fuses jump out when the pump is switched on	Wrong or too nimble fuses	Insert passive fuses with the correct current rating.
4. Motor protection switch trips	Wrong setting	Set correct current value +10% (see Technical Data)
5. Centrifugal pump cannot be switched on from the pool	- Switching tube has a kink in it - Fuse / power supply - Motor protection switch - Switching tube too long - Water in the switching tube	Check whether the pump can be switched from the switchgear box. - Eliminate causes in accordance with chapter 4 . - Shorten switching tube, if possible. - Blow through the switching tube from the swimming pool end
6. Air valve leaks	dirty	Screw the air valve off and wash it out during normal operation. Replace it, if necessary. <b>Note:</b> The air valve must be located above the water surface.

## 8 Shutdown / Overwintering



### Warning! Risk of damage!

If there is a risk of freezing, then the facility must be made winterproof. For this observe the following recommendations:

### 8.1 Empty the pool

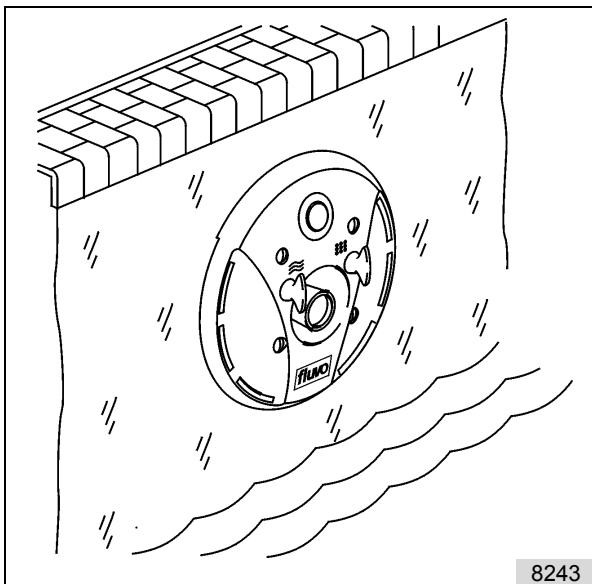

fig. 36



### Warning! Risk of damage!

Make sure you have protected the whole swimming complex adequately against frost. Observe the instructions issued by the manufacturer of the pool!

- Empty all the water out of the pool,
- or let the water out at least until it is 15-20cm below the level of the jet head.
- Switch off the master switch!

### 8.2 Face plate assembly overwintering

Remove the face plate assembly and store at room temperature.

## 8.3 Draining the pump

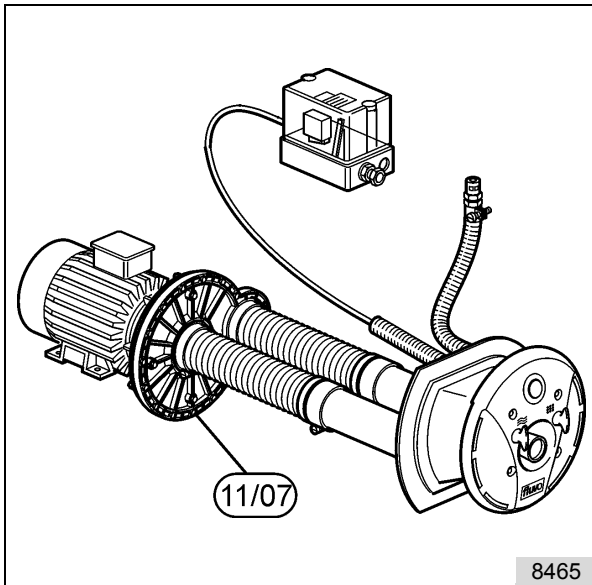

fig. 37

- 07 O-Ring
- 11 Plug screw

Screw out the plug screw (11) and drain the water.



### **Warning! Risk of damage!**

Make sure that all the water runs off! Also drain the pipework connected to the pump, if any!

Then screw the plug screw (11) back in again with a new O-ring (07).  
When restarting please observe the instructions in section 6.

## 9 Maintenance and Repair

### 9.1 General

All work on the counter-current unit must be carried out only if the pump has been drained and the control unit and pump motor have been disconnected from the mains and secured against unintentional reconnection.

### 9.2 Maintenance

- The counter-current unit is largely maintenance-free.
- Make sure that all the parts of the counter-current unit are kept clean.
- The gaskets on the motor shaft must be checked at regular intervals (at least once a year) by a trained engineer. If necessary, they must be replaced by original spare parts.

### 9.3 Repairs

- For any necessary repairs to the counter-current unit please observe the instructions for installation and start-up in this manual.
- Use exclusively original spare parts when carrying out repairs to the counter-current unit.

## 10 Spare parts

In the following spare parts list there are all the parts required for your counter-current unit. When ordering spare parts please specify the pump number and the order number of the individual part(s) in this list.

## 11 Spare Parts List and Drawing

### 11.1 Spare Parts List

Pos.	Best. Nr. No. de réf. Order No.	Bezeichnung	Désignation	Description	Stck. Nbre. Qty.	Bemerkung Remarque Remark
01.1	365445	Wechselstrom-Motor	Moteur à courant alternatif	1-phase AC motor	1	1,5 kW IEC 38 230V
01.7	360966	Drehstrom-Motor	Moteur à courant triphasé	3-phase AC motor	1	1,5 kW IEC 38 400/230V
01.3	365449	Wechselstrom-Motor	Moteur à courant alternatif	1-phase AC motor	1	1,9 kW IEC 38 230V
01.9	362185	Drehstrom-Motor	Moteur à courant triphasé	3-phase AC motor	1	1,9 kW IEC 38 400/230V
01.1 5	365447	Drehstrom-Motor	Moteur à courant triphasé	3-phase AC motor	1	3 kW IEC 38 400/230V
02.1	89083	Schaltkasten Wechselstrom	Coffret électrique courant alternatif	Switch cabinet 1-phase AC	1	1,5 kW IEC 38 230V
02.3	89075	Schaltkasten Drehstrom	Coffret électrique courant triphasé	Switch cabinet 3-phase AC	1	1,5 kW IEC 38 400/230V
02.2	89096	Schaltkasten Wechselstrom	Coffret électrique courant alternatif	Switch cabinet 1-phase AC	1	1,9 kW IEC 38 230V
02.4	89088	Schaltkasten Drehstrom	Coffret électrique courant triphasé	Switch cabinet 3-phase AC	1	1,9 kW IEC 38 400/230V
02.5	89125	Schaltkasten Drehstrom	Coffret électrique courant triphasé	Switch cabinet 3-phase AC	1	3 kW IEC 38 400/230V
03	R47505	Spiralgehäuse	Carter spiralé	Spiral housing	1	
04	21140	Gleiringdichtung	Joint mécanique	Mechanical seal	1	
05	51066	Unterlegscheibe	Rondelle	Distance washer	1	
06.1	51047	Lauftrad	Turbine	Impeller		1,5 kW Ø 105
06.3	51021	Lauftrad	Turbine	Impeller		1,9 kW Ø 110
06.4	51022	Lauftrad	Turbine	Impeller		3 kW Ø 125
07	24133	O-Ring	Joint torique	O-ring	3	10,0 x 2,0
08.1	56033	Lauftradschraube	Vis turbine	Impeller screw	1	
09	22113	Flachdichtung	Joint plat	Clamp gasket	1	
10.1	51007	Saugdeckel	Carter aspiration	Suction cover	1	
11	11104	Verschlusschraube	Bouchon fileté	Plug screw	2	G1/4"
12.1	16144	Schlauchschelle	Collier de serrage	Pipe clamp	2	S70/25 SKZ

Pos.	Best. Nr. No. de réf. Order No.	Bezeichnung	Désignation	Description	Stck. Nbre. Qty.	Bemerkung Remarque Remark
12.3	16097	Schlauschelle	Collier de serrage	Pipe clamp	2	S86/25 SKZ
13.1	16095	Schlauch	Tuyau flexible	Pipe	1	Ø 60 x 300 mm
14	55793	Schlauchverb.-Stutzen	Tuyau raccord	Adapter	1	
16.1	16099	Schlauch	Tuyau flexible	Hose	1	Ø 75 x 300 mm
20.6	94421	Einbausatz	Pièce à sceller	Installation kit	1	
21.2	92196	Schlauchkupplung	Accouplement de tuyau	Hose coupling	1	
22	45161	Klemmring	Bague de serrage	Clamp ring	1	
26	12181	Sechskantmutter	Ecrou six pans	Hexagon nut	8	M 8
26.2	12192	Sechskantmutter	Ecrou six pans	Hexagon nut	7	M10
28	56031	Rückschlagventil	Clapet anti-retour	Non-return valve	1	
29.2	56055	Übergangsnippel	Embout de réduction mâle		1	
31.2	16220	Schalterschlauch	Tuyau de commande	Switching tube	1	
32	22235	Flachdichtung	Joint plat	Clamp gasket	1	200 x 150 x 2 mm
35.1	92192	Düsenkopf	Tête de buse complète	Face plate assembly	1	
36	65032	Drehgriff Luftregulier.	Bouton régulation air	Air supply regulator knob	1	
37	65033	Drehgriff Mengenreg.	Bouton régulation débit	Volume regulator knob	1	
38	56232	Düsengehäuse	Tête de buse	Face plate	1	
39.2	22227	Flachdichtung	Joint plat	Clamp gasket	1	250 x 150 x 2 mm
40	56035	Düse	Buse	Nozzle	1	
41	56050	Kugelgleitring	Anneau de glissement à boule	Nozzle clamp seal	1	
42	15103	Druckfeder	Ressort de pression	Pressure spring	4	
43.1	10401	Schneidschraube	Vis coupante	Socket head cap screw	3	5,5 x 25
43.2	56036	Gehäuse	Boîtier	Housing	1	
44	13154	Zylinderkerbstift	Goupille en cochée cylindrique	Locking pin	1	
45	55602	Welle f. Luftregelung	Broche de régulation d'air	Shaft for air regulator	1	
46	22008	Flachdichtung	Joint plat	Clamp gasket	1	16 x 8 x 3
47	56775	Bundhülse	Douille à embase	Shaft collar	1	
48	57952	Zentrierhülse	Douille de centrage	Nozzle case sleeve	1	
49	56682	Gewindehülse	Douille filetée	Threaded sleeve	1	
50	23073	Dichtung	Joint	Gasket	2	
51	56681	Gleitmutter	Ecrou-coulisseau	Regulator nut	1	
53	56070	Drosselklappe	Vanne papillon	Regulating flap	1	
54	13226	Zylinderkerbstift	Goupille en cochée cylindrique	Locking pin	1	

Pos.	Best. Nr. No. de réf. Order No.	Bezeichnung	Désignation	Description	Stck. Nbre. Qty.	Bemerkung Remarque Remark
55	56680	Verstellspindel	Broche de réglage	Water regulator shaft	1	
56	67122	Bef. Satz Luftventil	Lot fix. pour valve à air	Air valve fixing bracket	1	
57	10561	Sechskantschraube	Vis six pans	Hexagon screw	1	M8 x 30
58	55272	Befestigungsschelle	Collier de fixation	Clamp	1	
59	67005	Spreizdübel	Cheville d'écartement	Rawl plug	1	SD 8
61	10244	Blechschaube	Vis parker	Tapping screw	3	4,2x13
62	56229	Haltering	Bague de retenue	Hold-ring	1	204 x 155 x 4
63	10626	Senkschraube	Vis à tête conique	Countersunk screw	7	M10 x 70
64	12397	Unterlegscheibe	Rondelle	Distance washer	7	10,5 x 21 x 2
67	51303	Haltering	Bague de retenue	Hold-ring	1	
68	56241	Haltering	Bague de retenue	Hold-ring	1	260 x 340 x 4
72	51306	Klemmring	Bague de serrage	Clamp ring	1	198 x 150 x 6
73	92022	Einbauelemente	Fittings	Fittings	1	
74	10518	Sechskantschraube	Vis six pans	Hexagon screw	8	M8 x 25
76	65072	Einschubsatz	Pièces à installer	Fittings	1	
77.2	92323	Einbauelemente	Fittings	Fittings	1	
78.2	92324	Einbauelemente	Fittings	Fittings	1	
83	12392	Unterlegscheibe	Rondelle	Distance washer	8	A 8
90.1	10880	Linsensenkschraube	Vis à tête conique bombée	Face plate screw	4	M8 x 100
90.2	10779	Linsensenkschraube	Vis à tête conique bombée	Face plate screw	4	M8 x 70
90.3	10539	Linsensenkschraube	Vis à tête conique bombée	Face plate screw	4	M8 x 45
92.4	94423	Einbausatz	Pièce à sceller	Insert set	1	
93	10530	Sechskantschraube	Vis six pans	Hexagon screw	15	M8 x 50
83	12392	Unterlegscheibe	Rondelle	Distance washer	15	8,4 x 16 x 1,6
26	12181	Sechskantmutter	Ecrou six pans	Hexagon nut	8	M8
96	55539	Abstandshülse	Douille d'écartement	Distance washer	1	
97	24424	V-Ring	Bague en V	V-ring	1	
98	22213	Flachdichtung	Joint plat	Clamp gasket	1	

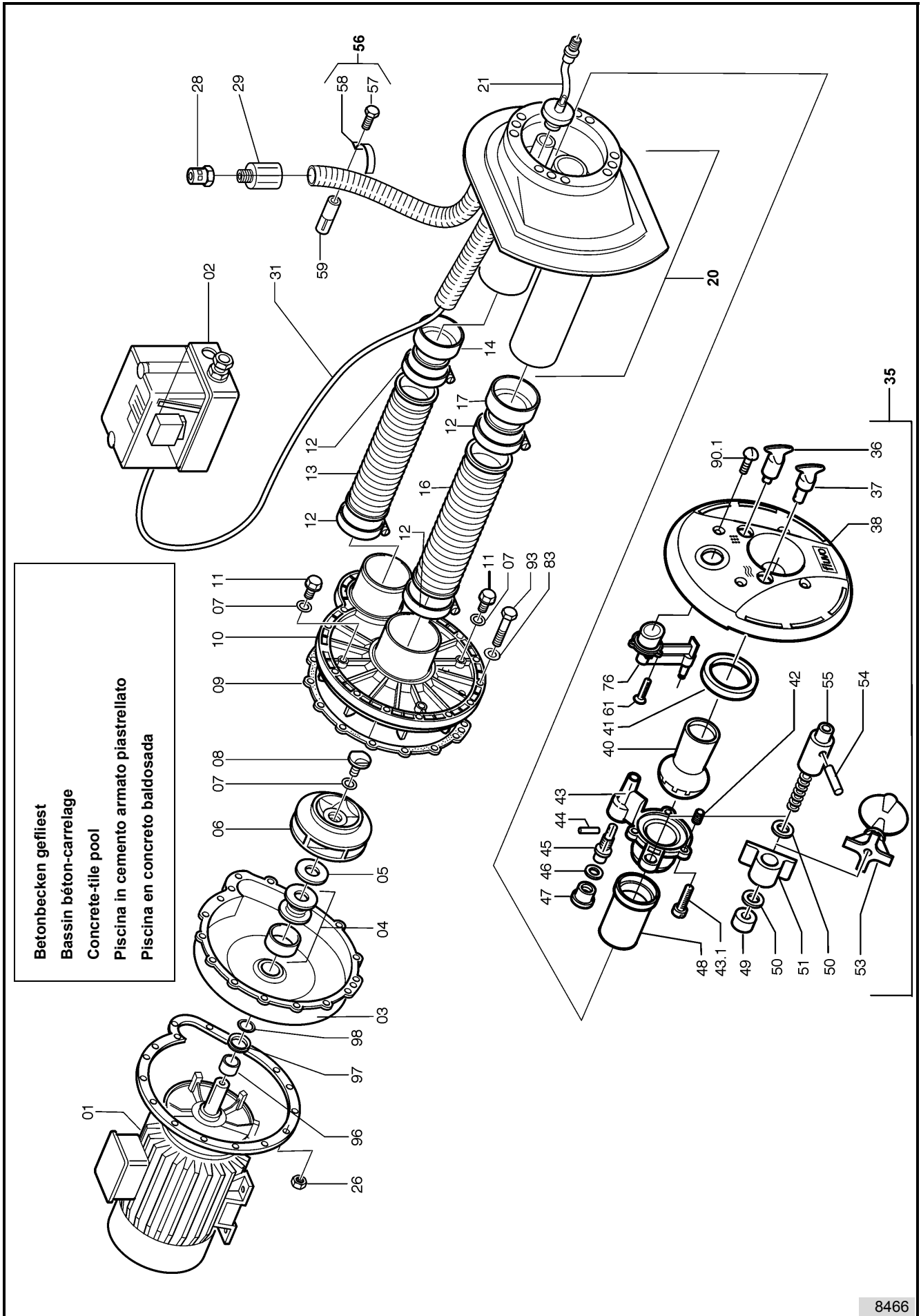

8466

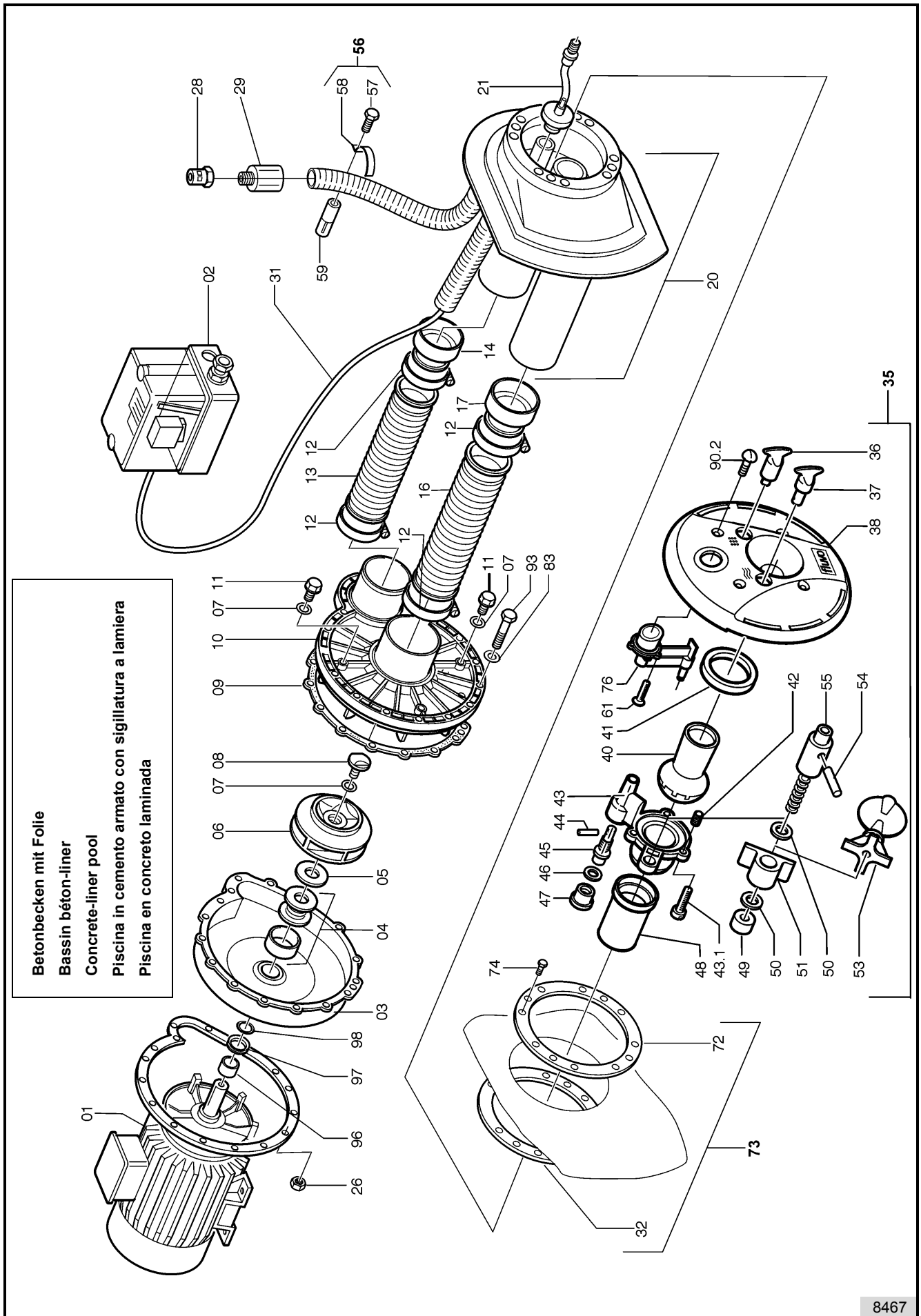

**Betonbecken mit Folie**  
**Bassin béton-liner**  
**Concrete-liner pool**  
**Piscina in cemento armato con sigillatura a lamiera**  
**Piscina en concreto laminada**

8467

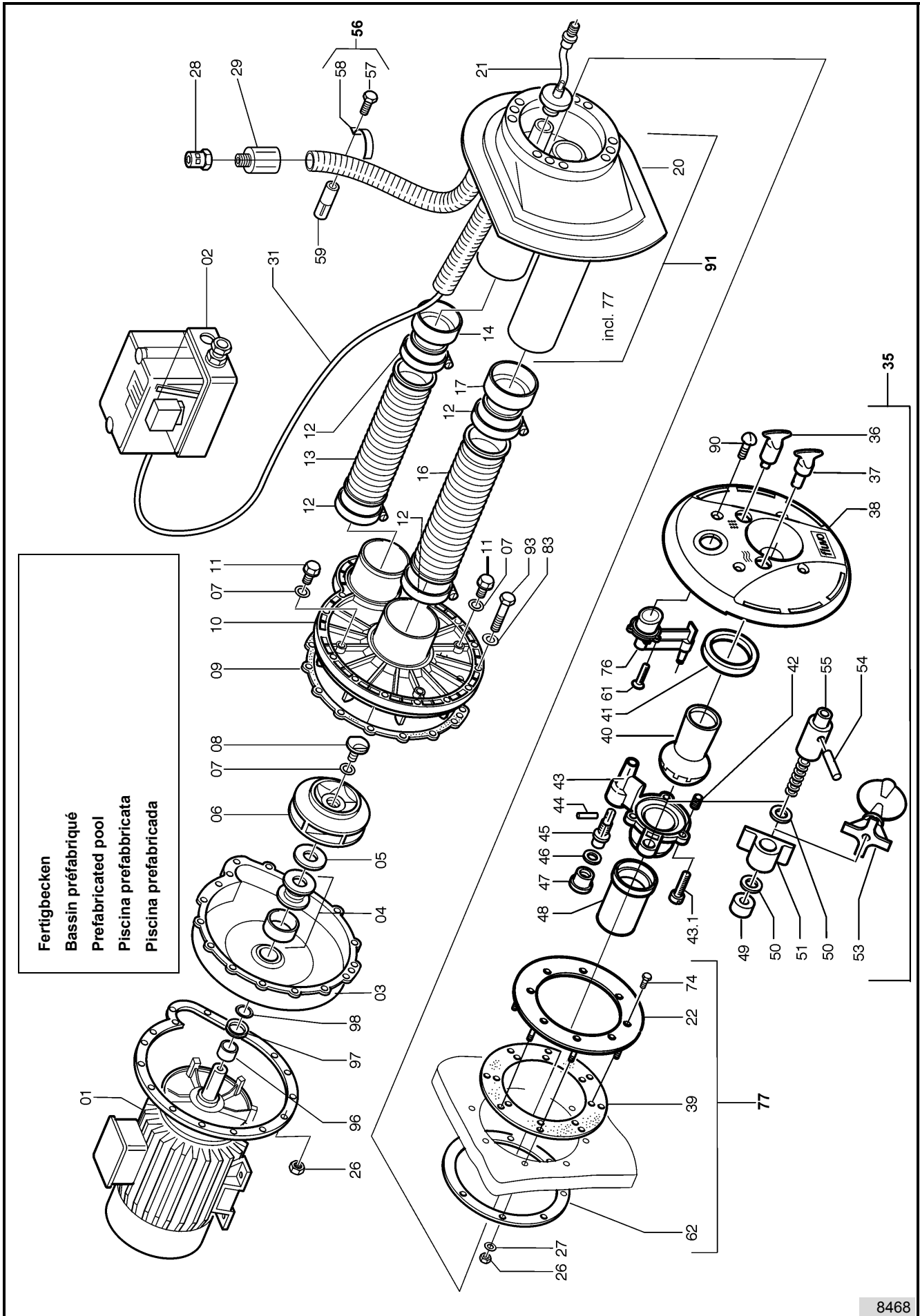

8468

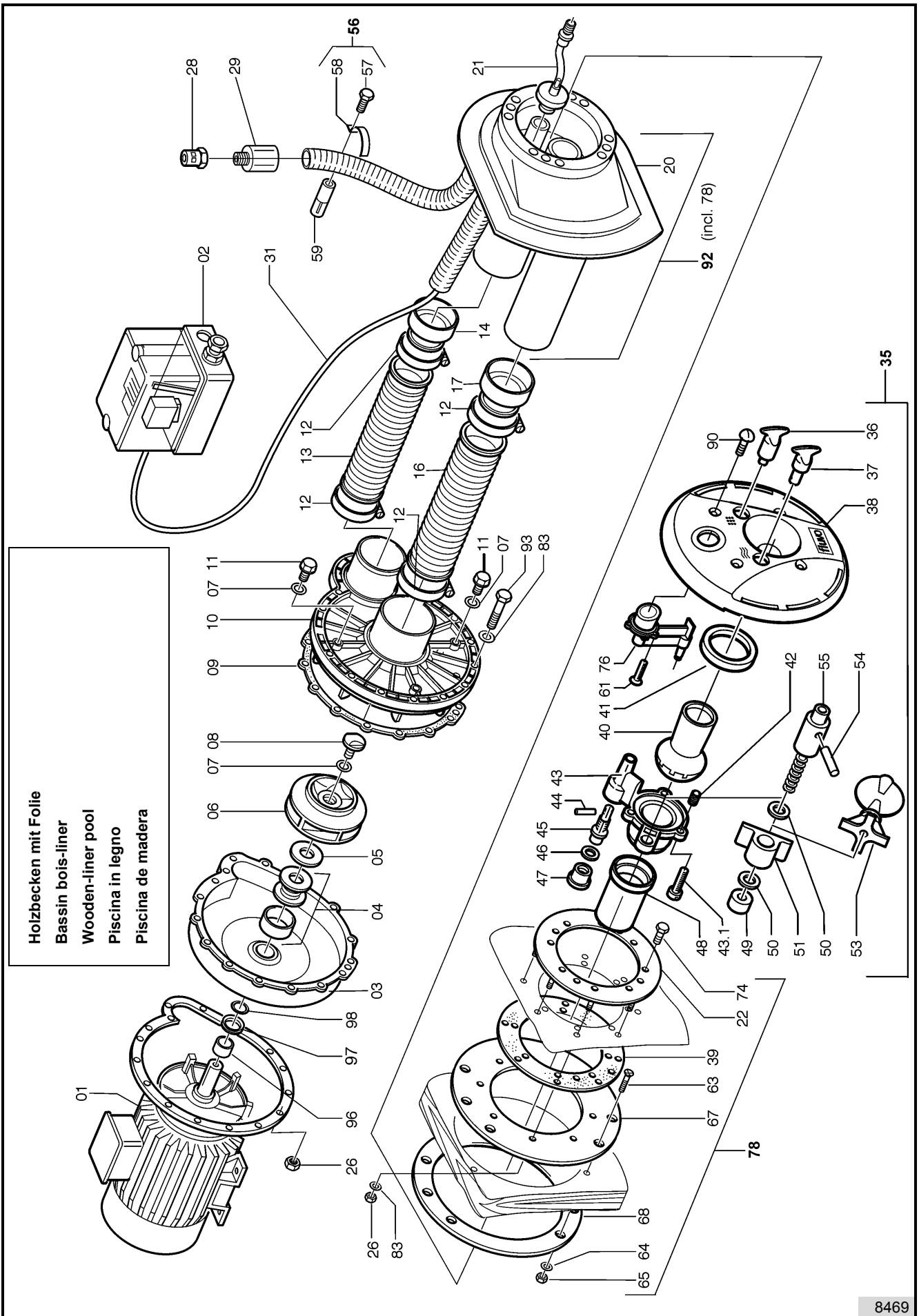

Holzbecken mit Folie  
Bassin bois-liner  
Wooden-liner pool  
Piscina in legno  
Piscina de madera

8469

**Schmalenberger GmbH + Co. KG**

Strömungstechnologie

Im Schelmen 9 - 11

D-72072 Tübingen / Germany

Telefon: +49 (0)7071 70 08 - 0

Telefax: +49 (0)7071 70 08 - 10

Internet: [www.fluvo.de](http://www.fluvo.de)

E-Mail: [info@schmalenberger.de](mailto:info@schmalenberger.de)

© 2009 Schmalenberger GmbH + Co. KG ; All rights reserved

This document is subject to change without notice